



User Manual

CD-3000 Series

Retrofit Control System

Model	Application
CD-3000-AE	Strand CD80® AMX or Advanced Electronic (AE) permanent installation racks.
CD-3000-AE-48RR	Strand CD80® AMX or Advanced Electronic (AE) 48 channel rolling racks
CD-3000-AE-96RR	Strand CD80® AMX or Advanced Electronic (AE) 96 channel rolling racks
CD-3000-SV	Strand CD80® Supervisor (SV) permanent installation racks
CD-3000-SV-48RR	Strand CD80® Supervisor (SV) 48 channel rolling racks
CD-3000-SV-96RR	Strand CD80® Supervisor (SV) 96 channel rolling racks
CD-3000-C21	Strand C21 permanent installation racks

JOHNSON SYSTEMS INC.

www.johnsonsystems.com



JOHNSON SYSTEMS INC.

"PROFESSIONAL LIGHT CONTROL PRODUCTS"

1923 Highfield Crescent S.E.
 Calgary, Alberta, Canada T2G 5M1
 tel: 403.287.8003
 fax: 403.287.9003
 e-mail: info@johnsonsystems.com
 website: www.johnsonsystems.com





Contents

Warranty	2
Introduction.....	3
Packaging & Contents.....	4
Installation	4
CD-3000 Backplane	12
Control Input/Output Connections	13
Control Module • MADD-96	15
User Interface	16
System Status • LED Indicators	17
System Status • LCD Display	17
Quick Programming Reference to System Configuration Menu Items.....	19
Detailed Programming of System Configuration Menu Items.....	20
Important Hard-key Information.....	35
Troubleshooting Reference	36

Warranty

The CD-3000 comes with a standard two (2) year limited warranty. Extended warranties of up to ten (10) years are available at the time of purchase.

For details visit www.johnsonsystems.com/warranties.htm.

For Technical Assistance

1. Refer to your product user manual. The most current revision is available online: www.johnsonsystems.com/literature.htm
2. Contact the “point-of-sale” dealer or distributor from which this product was originally purchased, and ask for technical assistance.
3. If neither of the above can provide you with the necessary information, please contact our factory via email (info@johnsonsystems.com) or phone (403-287-8003) during business hours (Monday to Friday, 8:00AM to 5:00PM MST).



Introduction



*CD-80® Supervisor
96 Channel Dimmer Rack
with CD-3000-SV Installed*



The **JSI CD-3000** is a next generation retrofit electronics package designed specifically for any vintage of Strand CD80® dimmer rack. The CD-3000 will replace the aging control electronics of the existing CD80® dimmer rack making system replacement unnecessary. This full- featured, ETL listed state-of-the-art unit provides a low cost digital interface to any of today's modern lighting communication protocols.



Designed to install in minutes with only a single screw driver, this elegant package has been designed for longevity and reliability with the end-user in mind. Intuitive LCD user interface combined with a single modular design makes the CD-3000 extremely user-friendly and easily serviceable. Advanced next generation hardware and software designs reduce stand-by power consumption to less than 1 Watt, allowing for compliance with the International Energy Agency's "One Watt Initiative" for standby power consumption.

Full featured, hi-resolution dimming with lightning fast response. Exclusive "lamp warming" techniques extends lamp life considerably. An environmentally and financially responsible solution that offers unsurpassed high performance in a matter in minutes!



CD-3000-AE



CD-3000-SV

Model	Application
CD-3000-AE	Strand CD80® AMX or Advanced Electronic (AE) permanent installation racks.
CD-3000-AE-48RR	Strand CD80® AMX or Advanced Electronic (AE) 48 channel rolling racks
CD-3000-AE-96RR	Strand CD80® AMX or Advanced Electronic (AE) 96 channel rolling racks
CD-3000-SV	Strand CD80® Supervisor (SV) permanent installation racks
CD-3000-SV-48RR	Strand CD80® Supervisor (SV) 48 channel rolling racks
CD-3000-SV-96RR	Strand CD80® Supervisor (SV) 96 channel rolling racks
CD-3000-C21	Strand C21 permanent installation racks



Packaging & Contents

Each CD-3000 Series retrofit system is shipped in a custom designed box for protection of the unit. Keep the box and packaging stored in a safe place. In the unlikely event that the system needs to be returned to the JSI Factory, the packaging will be required to prevent shipping damage and maintain warranty.

Each CD-3000 Series system includes all of the hardware required to complete the retrofit.

Installation

CD-3000-AE

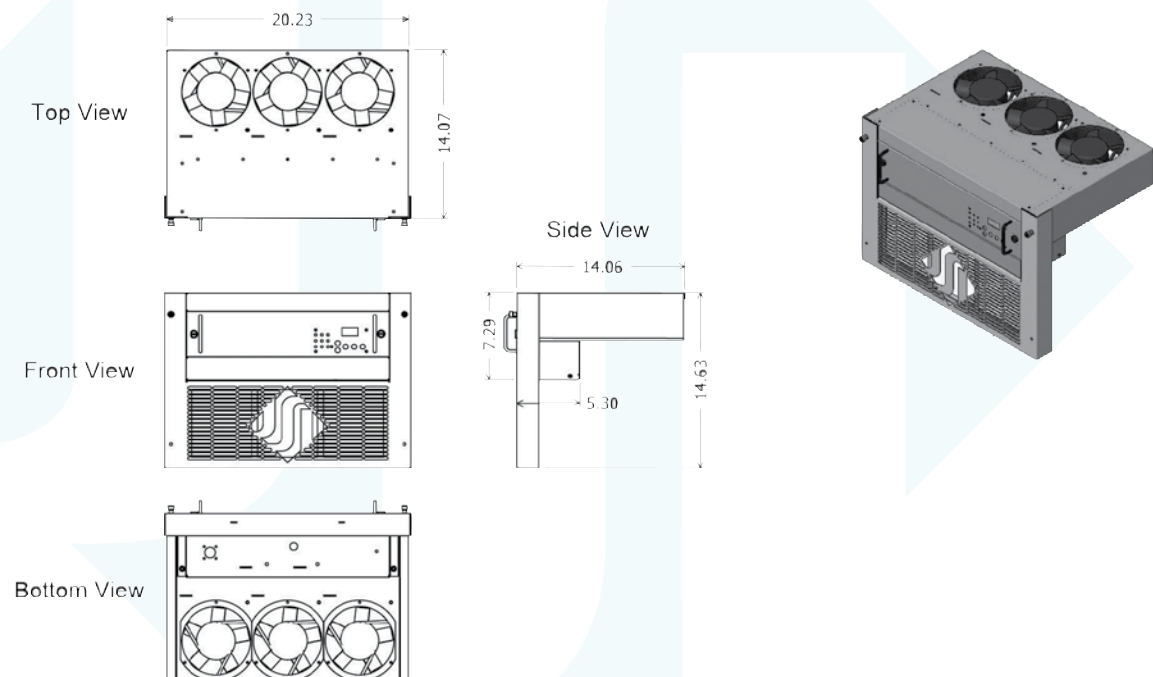

- Disconnect (turn off) the power supply to the Strand CD80® dimmer rack(s) and rack processor electronics. Some systems may have their processor electronics powered by an isolated (separate) feed.



WARNING! Verify all power is disconnected (turned off) before proceeding.

Removal of the Old Processor Housing

- Remove the upper ventilation grill and lower air filter grill from the CD-80® rack and set them aside.
- Inspect the lower portion of the dimmer rack for any wiring, AC line voltage bussing, conduit, etc. that could prevent the smooth removal of the old processor housing. Take the appropriate measures to remove any obstructions being careful not to strain or remove any of the control wiring that terminates on the rear of the existing processor housing.
- Inspect the upper portion of the dimmer rack for any similar obstructions. Pay particular attention to the upper left side of the dimmer rack. This portion of the rack contains hardware, circuitry and wiring that must be retained in order to retrofit the rack as designed.

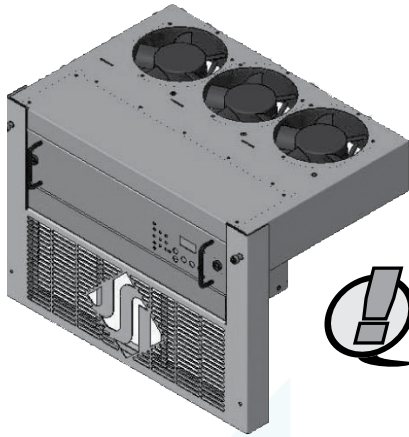

- Unscrew the two mounting (thumb) screws that hold the old processor housing in place. Slowly remove the old card cage, taking care not to strain or disconnect any of the original CD-80® wiring. Carefully observe and label as necessary all wiring as to its location and polarity.
- If you are not familiar with the Strand CD-80® dimmer rack processor electronics and wiring, it is strongly advised that you take a few minutes to look at the back of the processor housing connections and compare it to the backplane on the CD-3000-AE. Do not disconnect any wiring until you are satisfied with how easy this is going to be.

NOTE: Never pull directly on the wires to remove connectors.

- Disconnect the power connector. This connector is a 9-position CPC (Circular Plastic Connector) plug (female - cable mount) and receptacle (male - chassis mount). It is black in color and approximately two (2) inches in length. It is located at the lower (rear) right-hand side of the old processor housing. Turn the locking ring counterclockwise to disconnect.
- Disconnect the four (4) 27-conductor control output cables. **Do not pull on the wire to disconnect.** Carefully apply pressure to the connector itself with either your fingers or preferably a small flat head screwdriver. Do not mix up the cable order or polarity.
- Disconnect the smaller 10-conductor connector. This connector and cable is not required on the CD-3000 retrofit and should be coiled up and wire-tied. Carefully set it aside inside the rack and keep it isolated from any AC line voltage.
- The old processor housing can now be set aside.

Installation of the new CD-3000-AE System

- Remove your new CD-3000-AE system from the box. **Leave the foam end caps in place to protect the unit from damage.**
- Familiarize yourself with the backplane, and low voltage control input/output connections. Refer to page 12 for details.
- Dress out all DMX and other low voltage connections to the backplane using the breakaway connectors provided. Be sure to isolate and protect all shield wires.
- Place the CD-3000-AE in front of the rack face down / backplane up. **Leave the foam end caps left in place to protect the unit from damage.**
- Connect the four (4) 27-conductor control output cables to the backplane in the same order and polarity in which they were removed. **Extra care should be taken not to bend or break any of the connector/header pins.** Damage to these pins may require replacement of the entire CD-3000 assembly and will not be considered warranty! Refer to page 10 for the connector pinout.
- Connect all other applicable low voltage control input/output connections to the backplane.
- Connect the 9-position CPC power connector. The connector is keyed, so the plug and receptacle must be aligned to mate properly. Once aligned, turn the locking ring clockwise until a "click" is heard and felt indicating that the connector is fully seated. Refer to page 10 for the connector pinout.

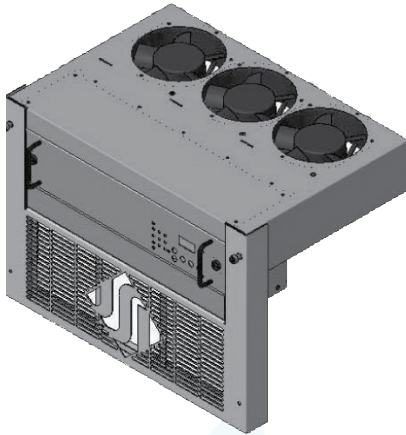

- Remove the protective foam caps.
- Place the CD-3000-AE onto the CD-80® dimmer rack guide rails located on each side and carefully slide the unit into place. Ensure that the CD-3000-AE is fully seated.
- Tighten the mounting (thumb) screws into the threaded speed clips mounted on the end of each of the guide rails. Replacement speed clips are provided in case the original ones are worn out or missing.
- Install the CD-3000-AE air filter grill assembly. Start the upper two (2) mounting (thumb) screws, located on the upper arms of the air filter grill assembly and screw into the CD-3000-AE chassis. Start the lower two (2) mounting (thumb) screws located on the lower portion of the air filter grill assembly and screw into the brackets at the bottom CD-80® dimmer rack. Once all four (4) mounting (thumb) screws are started, tighten them down and verify the assembly is fully seated. Be sure not to over-tighten or cross-thread the mounting screws. The air filter should be removed from the rack and cleaned annually using compressed air.

The air filter grill assembly is precisely engineered to allow for safe air flow and filtration. The air filter and frame can be easily removed for cleaning and maintenance. Pushing up on the filter frame will free it to be pivoted out. Always ensure the filter frame is fully seated and secure before installing the CD-3000 air filter grill assembly. The air filter should be removed from the rack and cleaned annually using compressed air.



WARNING! Never connect power with the air filter grill assembly removed.

- Reinstall the upper ventilation grill assembly onto the dimmer rack.
- Connect (turn on) the power supply to the Strand CD80® dimmer rack(s) and CD-3000.
- Verify system status LED indicators and LCD display. Refer to page 17 and 18 for details.
- Refer to the programming section of this manual for system setup. Refer to page 19 to 34 for details.
- Test the system thoroughly to ensure all wiring terminations are functioning and the control signals to the dimmers have the correct phase referencing.
- Verify fan operation. The fans are triggered on at 3% DMX input control, and stay on as long as the DMX is at 3% or greater. When the DMX input is brought down below 3%, there is a 5 minute timeout for the fans to turn off.

CD-3000-AE-48RR

- Follow the same installation procedure as CD-3000-AE.

CD-3000-AE-96RR

- Follow the same installation procedure as CD-3000-AE for the primary processor side of the rack.
- The CD-3000-AE-96RR is supplied with a fan housing assembly used to cool the secondary side of the rolling rack.
- The CD-3000-AE-96RR is supplied with a fan wiring harness used to supply power to the fans in the fan housing assembly.



- Remove the old fan housing similarly to the processor housing and set aside.
- Place the fan housing assembly in front of the rack with the foam end caps left in place to protect the unit from damage.
- Connect the fan wiring harness to the connectors supplied on the fan housing assembly.
- Remove the protective foam caps.
- Install the fan housing assembly and ventilation grill assembly similarly to the CD-3000-AE.

CD-3000-SV

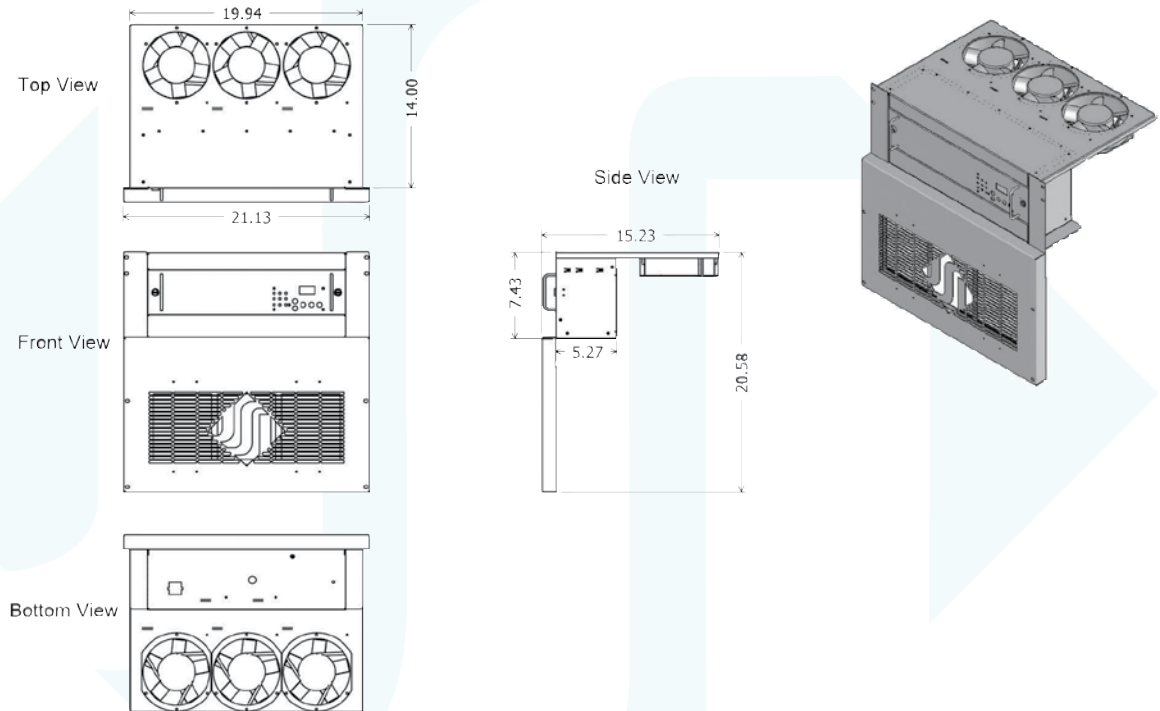

- Disconnect (turn off) the power supply to the Strand CD80® dimmer rack(s) and rack processor electronics. Some systems may have their processor electronics powered by an isolated (separate) feed.



WARNING! Verify all power is disconnected (turned off) before proceeding.

Removal of the Old Processor Housing

- Remove the screws located on left and right sides of the processor housing.
- Slowly pull the processor housing partway out to expose the control cable connections.
- If you are not familiar with the Strand CD-80® dimmer rack processor electronics and wiring, it is strongly advised that you take a few minutes to look at the control cables connected to the circuit board on top of the processor housing and compare it to the backplane on the CD-3000-SV. Do not disconnect any wiring until you are satisfied with how easy this is going to be.



NOTE: Never pull directly on the wires to remove connectors.

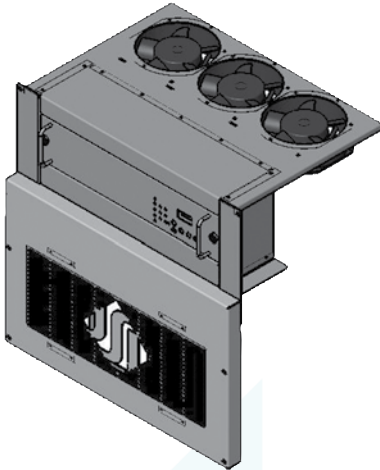

- Note the location and function of all control cables landed on the circuit board on top of the processor housing. Label cables if necessary. These control cables may now be disconnected from the circuit board. Disconnect the "TOP COLUMNS" and "BOTTOM COLUMNS" control cables making sure they have their respective labels.
- The processor housing can now be carefully withdrawn from the rack, threading the control cables out from under the plexiglass cover. The back end must be supported as it is withdrawn so the power connector (square, white, 12-position connector) located at the left rear can be disconnected. To disconnect, squeeze the tabs on both sides of the connector together and pull out. The processor housing may now be fully removed and set aside.
- Unscrew and remove the blank panel located under the slot for the processor housing.
- Unscrew and remove the air filter grill on the fan housing located above the slot for the processor housing.
- Unscrew and remove the fan housing. There is a Molex connector at the rear of the fan housing that must be disconnected. This connector and cable is not required on the CD-3000 retrofit and should be coiled up and wire-tied to the wiring harness it emerges from. Keep it isolated from any AC line voltage.
- With everything removed, look at the fuse block in the back of the rack and check the phasing. The wires landed on the bottom of the fuse block lead to the processor power connector. The black wire should be on Phase "A", red on Phase "B", and blue on Phase "C". Correct if necessary.

Installation of the new CD-3000-SV System

- Remove your new CD-3000-SV system from the box. **Leave the foam end caps in place to protect the unit from damage.**
- Familiarize yourself with the backplane, and low voltage control input/output connections. Refer to page 12 for details.
- Dress out all DMX and other low voltage connections to the backplane using the breakaway connectors provided. Be sure to isolate and protect all shield wires.
- Place the CD-3000-AE in front of the rack face down / backplane up. **Leave the foam end caps left in place to protect the unit from damage.**
- Connect the "TOP COLUMNS" and "BOTTOM COLUMNS" control cables to their designated locations on the backplane. Lock in place using the ejection clamps on the connector. Refer to page 11 for the connector pinout.

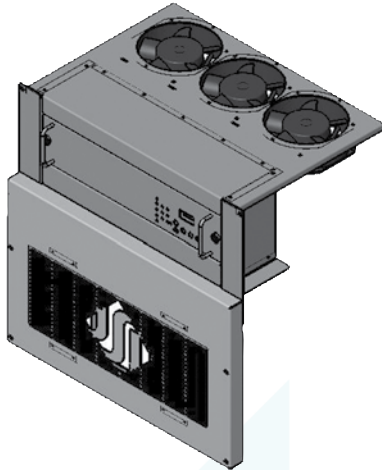

- Connect all other applicable low voltage control input/output connections to the backplane.
- Connect the power connector (square, white, 12-position connector) into its mate mounted on the CD-3000-SV chassis. The connector is keyed so it can only be inserted one way. Push the connector in until a “click” is heard and the clamps locked indicating that the connector is fully seated. Refer to page 11 for the connector pinout.
- Carefully slide the CD-3000-SV into the rack using the rails for the old fan housing. Be sure not to pinch or stress any wires or cables. Secure in place using the four (4) 10-32 x 3/8” screws provided.
- Place the new air filter grill assembly over the bottom opening of the rack. Secure in place using the four (4) 10-32 x 1 3/4” screws provided. The air filter grill assembly is precisely engineered to allow for safe air flow and filtration. The air filter and frame can be easily removed for cleaning and maintenance. Pushing up on the filter frame will free it to be pivoted out. Always ensure the filter frame is fully seated and secure before installing the CD-3000 air filter grill assembly. The air filter should be removed from the rack and cleaned annually using compressed air.



WARNING! Never connect power with the air filter grill assembly removed.

- Connect (turn on) the power supply to the Strand CD80® dimmer rack(s) and CD-3000.
- Verify system status LED indicators and LCD display. Refer to page 17 and 18 for details.
- Refer to the programming section of this manual for system setup. Refer to page 19 to 34 for details.
- Test the system thoroughly to ensure all wiring terminations are functioning and the control signals to the dimmers have the correct phase referencing.
- Verify fan operation. The fans are triggered on at 6% DMX input control, and stay on as long as the DMX is at 6% or greater. When the DMX input is brought down below 6%, there is a 5 minute timeout for the fans to turn off.

CD-3000-SV-48RR

- In development.

CD-3000-SV-96RR

- In development.

CD-3000-C21

- In development.

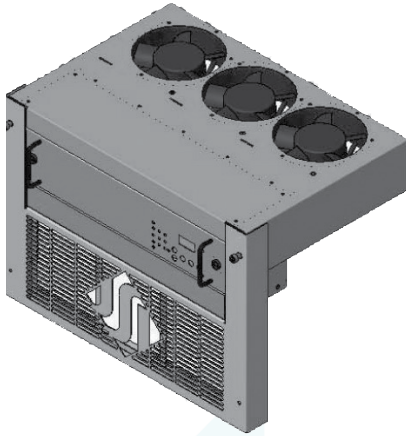

CD-3000-AE Dimmer Control Cable Pinout

J1AE Connector		J2AE Connector		J3AE Connector		J4AE Connector	
PIN	FUNCTION	PIN	FUNCTION	PIN	FUNCTION	PIN	FUNCTION
1	Dimmer 24	1	Dimmer 48	1	Dimmer 72	1	Dimmer 96
2	Dimmer 23	2	Dimmer 47	2	Dimmer 71	2	Dimmer 95
3	Dimmer 18	3	Dimmer 42	3	Dimmer 66	3	Dimmer 90
4	Dimmer 17	4	Dimmer 41	4	Dimmer 65	4	Dimmer 89
5	Dimmer 12	5	Dimmer 36	5	Dimmer 60	5	Dimmer 84
6	Dimmer 11	6	Dimmer 35	6	Dimmer 59	6	Dimmer 83
7	Dimmer 6	7	Dimmer 30	7	Dimmer 54	7	Dimmer 78
8	Dimmer 5	8	Dimmer 29	8	Dimmer 53	8	Dimmer 77
9	Dimmer 22	9	Dimmer 46	9	Dimmer 70	9	Dimmer 94
10	Dimmer 21	10	Dimmer 45	10	Dimmer 69	10	Dimmer 93
11	Dimmer 16	11	Dimmer 40	11	Dimmer 64	11	Dimmer 88
12	Dimmer 15	12	Dimmer 39	12	Dimmer 63	12	Dimmer 87
13	Common	13	Common	13	Common	13	Common
14	Common	14	Common	14	Common	14	Common
15	Common	15	Common	15	Common	15	Common
16	Dimmer 10	16	Dimmer 34	16	Dimmer 58	16	Dimmer 82
17	Dimmer 9	17	Dimmer 33	17	Dimmer 57	17	Dimmer 81
18	Dimmer 4	18	Dimmer 28	18	Dimmer 52	18	Dimmer 76
19	Dimmer 3	19	Dimmer 27	19	Dimmer 51	19	Dimmer 75
20	Dimmer 20	20	Dimmer 44	20	Dimmer 68	20	Dimmer 92
21	Dimmer 19	21	Dimmer 43	21	Dimmer 67	21	Dimmer 91
22	Dimmer 14	22	Dimmer 38	22	Dimmer 62	22	Dimmer 86
23	Dimmer 13	23	Dimmer 37	23	Dimmer 61	23	Dimmer 85
24	Dimmer 8	24	Dimmer 32	24	Dimmer 56	24	Dimmer 80
25	Dimmer 7	25	Dimmer 31	25	Dimmer 55	25	Dimmer 79
26	Dimmer 2	26	Dimmer 26	26	Dimmer 50	26	Dimmer 74
27	Dimmer 1	27	Dimmer 25	27	Dimmer 49	27	Dimmer 73

CD-3000-AE Power Connector Pinout

PIN	FUNCTION
1	Ground
2	No Connect
3	Neutral
4	No Connect
5	Phase C
6	No Connect
7	Phase A
8	No Connect
9	Phase B

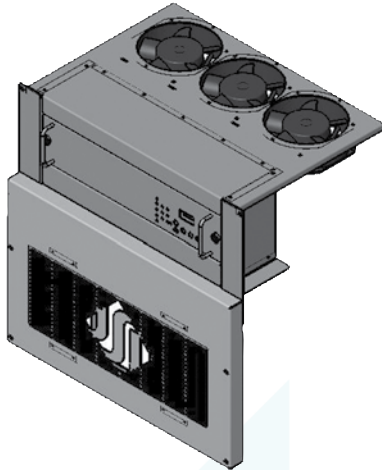

CD-3000-SV Dimmer Control Cable Pinout

#1 Top Columns		#2 Top Columns		#3 Top Columns	
PIN	FUNCTION	PIN	FUNCTION	PIN	FUNCTION
1	Dimmer 1	1	Dimmer 3	1	Dimmer 5
2	Dimmer 2	2	Dimmer 4	2	Dimmer 6
3	Dimmer 13	3	Dimmer 15	3	Dimmer 17
4	Dimmer 14	4	Dimmer 16	4	Dimmer 18
5	Dimmer 25	5	Dimmer 27	5	Dimmer 29
6	Dimmer 26	6	Dimmer 28	6	Dimmer 30
7	Dimmer 37	7	Dimmer 39	7	Dimmer 41
8	Dimmer 38	8	Dimmer 40	8	Dimmer 42
9	V+	9	V+	9	V+
10	NC	10	NC	10	NC
#4 Top Columns		#5 Top Columns		#6 Top Columns	
PIN	FUNCTION	PIN	FUNCTION	PIN	FUNCTION
1	Dimmer 7	1	Dimmer 9	1	Dimmer 11
2	Dimmer 8	2	Dimmer 10	2	Dimmer 12
3	Dimmer 19	3	Dimmer 21	3	Dimmer 23
4	Dimmer 20	4	Dimmer 22	4	Dimmer 24
5	Dimmer 31	5	Dimmer 33	5	Dimmer 35
6	Dimmer 32	6	Dimmer 34	6	Dimmer 36
7	Dimmer 43	7	Dimmer 45	7	Dimmer 47
8	Dimmer 44	8	Dimmer 46	8	Dimmer 48
9	V+	9	V+	9	V+
10	NC	10	NC	10	NC
#1 Bottom Columns		#2 Bottom Columns		#3 Bottom Columns	
PIN	FUNCTION	PIN	FUNCTION	PIN	FUNCTION
1	Dimmer 49	1	Dimmer 51	1	Dimmer 53
2	Dimmer 50	2	Dimmer 52	2	Dimmer 54
3	Dimmer 61	3	Dimmer 63	3	Dimmer 65
4	Dimmer 62	4	Dimmer 64	4	Dimmer 66
5	Dimmer 73	5	Dimmer 75	5	Dimmer 77
6	Dimmer 74	6	Dimmer 76	6	Dimmer 78
7	Dimmer 85	7	Dimmer 87	7	Dimmer 89
8	Dimmer 86	8	Dimmer 88	8	Dimmer 90
9	V+	9	V+	9	V+
10	NC	10	NC	10	NC
#4 Bottom Columns		#5 Bottom Columns		#6 Bottom Columns	
PIN	FUNCTION	PIN	FUNCTION	PIN	FUNCTION
1	Dimmer 55	1	Dimmer 57	1	Dimmer 59
2	Dimmer 56	2	Dimmer 58	2	Dimmer 60
3	Dimmer 67	3	Dimmer 69	3	Dimmer 71
4	Dimmer 68	4	Dimmer 70	4	Dimmer 72
5	Dimmer 79	5	Dimmer 81	5	Dimmer 83
6	Dimmer 80	6	Dimmer 82	6	Dimmer 84
7	Dimmer 91	7	Dimmer 93	7	Dimmer 95
8	Dimmer 93	8	Dimmer 94	8	Dimmer 96
9	V+	9	V+	9	V+
10	NC	10	NC	10	NC

CD-3000-SV Power Connector Pinout

PIN	FUNCTION
1	Phase C
2	Phase B
3	Phase A
4	Neutral
5	No Connect
6	Ground
7	O/T N.C. (V+)
8	O/T N.C.
9	O/T N.O.
10	O/T N.C. (COM)
11	No Connect
12	No Connect



CD-3000 Backplane

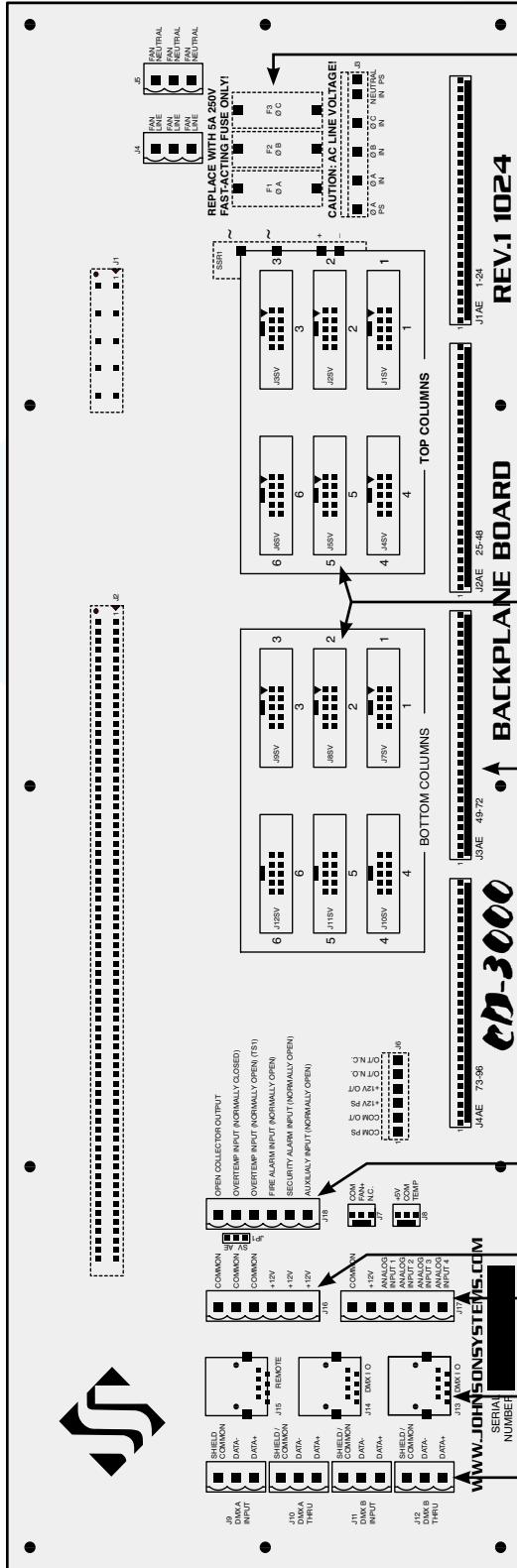

Internal Fuses (3)
Replace with 5A 250V
Fast-Acting Fuse Only!



WARNING! Verify all power is disconnected (turned off) before checking or servicing fuses.

CD-3000-SV Control Output Connectors (12)

CD-3000-AE Control Output Connectors (4)

Input / Output Contacts Connector

+12VDC Power Supply Output Connector

0-10VDC Analog Input Connector

RJ45 DMX I/O Connectors (2). Used to connect (daisy-chain) DMX A and DMX B between CD-3000 systems in multi-rack installations.

Dual DMX Input and Thru Connectors



Control Input/Output Connections

All CD-3000 systems come with a variety of control input and output (I/O) capabilities. All I/O connections are terminated on the Backplane.

Breakaway type connectors are supplied for all I/O connections.

- Use wire size #28 to #12 AWG. Strip insulation length to 0.3" (7.5mm).
- Torque terminations to 3.6 IN-LBS (0.4 NM).



NOTE: For connection use copper wire only, rated for 167°F (75°C) minimum.

Dual DMX Input and Thru

- DMX A (SHIELD/COMMON, DATA-, DATA+) is terminated on the J9 and J10 connectors.
- DMX B (SHIELD/COMMON, DATA-, DATA+) is terminated on the J11 and J12 connectors.
- For multi-rack CD-3000 installations, a 10 foot (3 meter) CAT 5e patch cable is supplied. This cable is used to daisy-chain the DMX A and DMX B between systems. The CAT 5e patch cable terminates to J13 and J14 connectors.
- Complies with USITT DMX512-A (ANSI E1.11 - 2008), standard protocol for digital data control.
- Recommended cable is Belden 9829, 9842, Cat 5 or equivalent (low-capacitance, twisted pair).
- Wiring must follow a daisy-chain topology.
- Maximum of 32 receiving devices on a single DMX line.
- Maximum cable length is 1,500 feet (455 meters).
- For more information, Google DMX, or visit:
<http://old.usitt.org/DMX512FAQ.aspx>



NOTE: Ensure only the last (end-of-line) DMX receiving device is terminated!

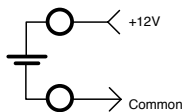

+12VDC Power Supply Output

- A regulated +12VDC power supply is available for powering external devices.
- Terminate on +12V and COMMON of J16 connector.
- External devices should not exceed the maximum combined current draw of 2 Amps.

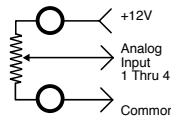

0-10VDC Analog Inputs or Load Shed Contact Inputs

- Four (4) analog inputs terminate on J17 connector.
- Inputs can be configured for normal or load shed mode of operation.
- Inputs can be patched to any combination of dimmer output circuits.
- Programmed in the "ANA MODE" and "ANA PAT" menus.

See page 26 for details.

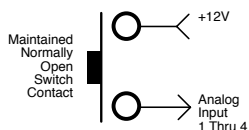

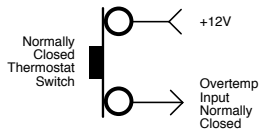

Over-Temperature Input (Normally Closed)

- Terminate (OVERTEMP INPUT (NORMALLY CLOSED)) on J18 connector.
- Disables all dimmer outputs when contact/switch is opened.
- Controlled via a maintained contact/switch to +12V.
- Connects to OEM wiring in Strand CD80® Supervisor (SV) racks via the power connector.

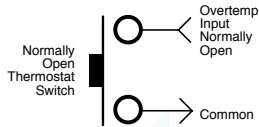

Over-Temperature Input (Normally Open) (TS1)

- Terminate (OVERTEMP INPUT (NORMALLY OPEN) (TS1)) on J18 connector.
- Disables all dimmer outputs when contact/switch is closed.
- Controlled via a maintained contact/switch to low-voltage common (COMMON).
- Connects to OEM wiring in Strand CD80® Supervisor (SV) racks via the power connector.
- Optionally connects to OEM wiring in Strand CD80® AMX or Advanced Electronic (AE) racks.

Connect to TS1 located on the upper left-hand side of the dimmer rack. Connect COM, also located on the upper left-hand side of the dimmer rack, to COMMON on the CD-3000 Backplane.

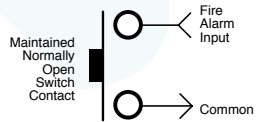

Fire Alarm Input (Normally Open)

- Terminate on J18 connector.
- Triggers selected channels to turn on when contact/switch is closed.
- Controlled via a maintained contact/switch to low-voltage common (COM).
- Programmed in the "F-ALARM" menu. See page 29 for details.

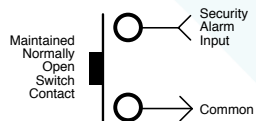

Security Alarm Input (Normally Open)

- Terminate on J18 connector.
- Triggers selected channels to cycle on and off at a 1 Hertz rate when contact/switch is closed.
- Controlled via a maintained contact/switch to low-voltage common (COM).
- Programmed in the "S-ALARM" menu. See page 28 for details.

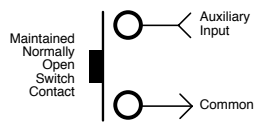

Auxiliary Input (Normally Open)

- Terminate on J18 connector.
- Triggers 1 of 20 presets when contact/switch is closed.
- Controlled via a maintained contact/switch to low-voltage common (COM).
- Programmed in the "AUX IN" menu. See page 28 for details.

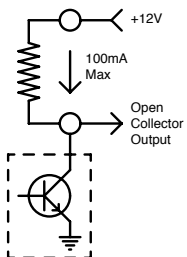

Open Collector Output

- Terminate on J18 connector.
- Sink up to 100mA.
- Trigger Solid State Relays (SSR) or other external devices.
- Controlled via DMX and/or Analog Input 4.
- Programmed in the "OC MODE" menu. See page 28 for details.



EEPROM
Memory Module

Control Module • MADD-96

(Multiple Application Dimmer Driver)

The MADD-96 is the central electronic control system (brain) for all CD-3000 Series retrofit systems. The MADD-96 is mounted in the Control Module. The Control Module can be removed by releasing the two (2) quarter-turn fasteners on each side. To release the fasteners, turn them a quarter-turn counter-clockwise using a flathead screwdriver. Once the fasteners are released, pull the module outwards using the two (2) handles on each side. To reinstall the Control Module, slide the metalwork through the guide rails on each side of the CD-3000 chassis and push it in until it is fully seated. You will hear and feel the Control Module snap into place. Once the Control Module is fully seated, the quarter-turn fasteners can be locked into place by lining the slot up horizontally and pushing it in with a thumb.

Located on the MADD-96 is a removable EEPROM memory module. The EEPROM slides into the PORT4 connector located on the upper left-hand side of the board. The EEPROM is used to backup important configuration settings and may be removed for safe storage. The EEPROM can also be used for firmware updates. Refer to menu items "EEPROM", "FW-LOAD", "RESTORE" and "BACKUP" on page 31 to 33 for further details.

CD-3000 Control Module

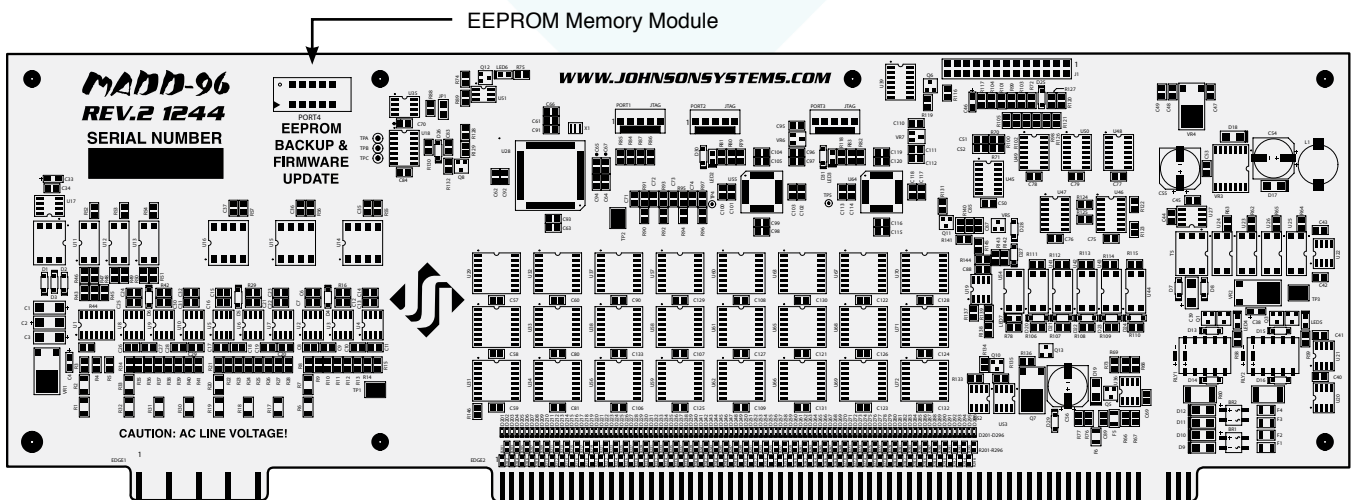
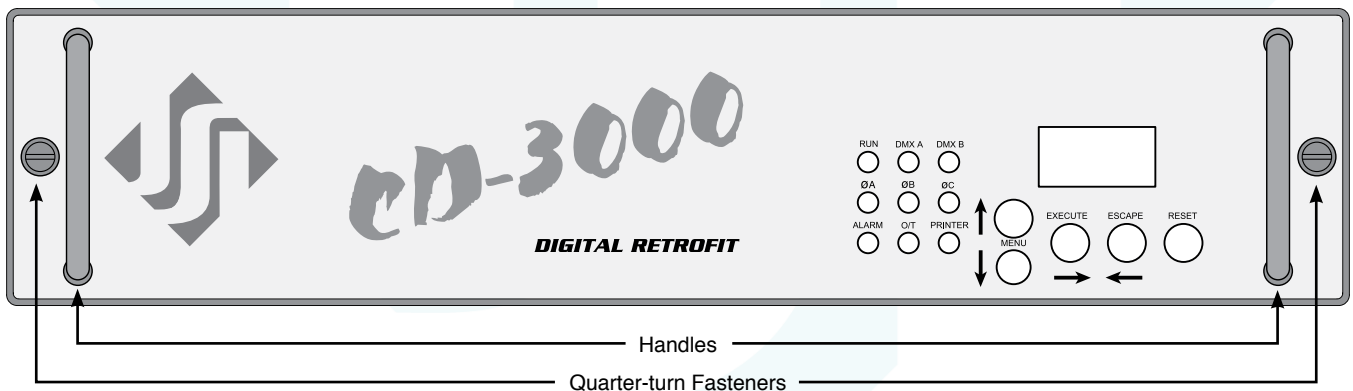

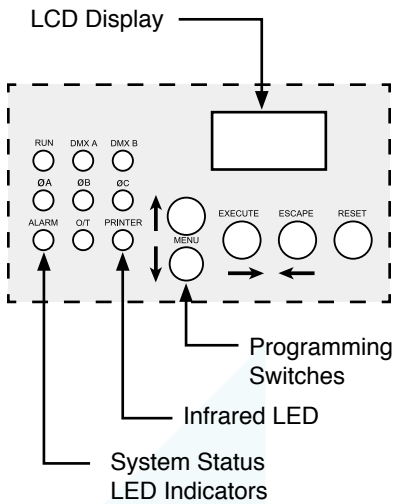

User Interface

All CD-3000 Series retrofit systems are equipped with a user interface. The user interface provides access to all programming and configuration settings. System status is easily visible on the LCD display and LED indicators. An infrared LED allows for printout of all system configuration settings when used with a hand held infrared printer (Johnson System Inc., Part Number: JS-IP).

All of the programming is accomplished using four (4) switches. Within a few minutes most users will find the menu structure very intuitive and easy to navigate. All configuration settings are automatically stored into EEPROM.

LCD Display

The LCD display is capable of displaying 2 lines of 8 Characters. A backlight automatically comes on when activity is sensed on the switches. The LCD contrast can be easily adjusted for optimum viewing. Refer to menu item "LCD VIEW" on page 34 for further details.

Programming Switches

The MENU UP/DOWN (↕) switches are used for navigating through the various system configuration menu items. They also allow for programming of other specific parameters within a selected menu. Pressing and holding either switch will speed up the scroll rate, which can be helpful to speed up the configuration time.

The EXECUTE switch is normally used to select/enter a menu item, advance forward within a selected menu item, or toggle between parameters within a selected menu item.

The ESCAPE switch is normally used to back up within a selected menu item one step at a time, or exit the menu completely.



NOTE: The programming switches can be locked out to prevent inadvertent configuration changes. To toggle between "LOCKED!!" and "UNLOCKED" press and hold down the EXECUTE and then ESCAPE switches at the same time for 4-5 seconds.

The RESET switch has two purposes. First, it allows for quick exit from a menu item after a programming change and automatically puts the system into normal run mode. Second, it provides a soft reboot for the systems microcontroller.



NOTE: A detailed procedure for programming all system configuration menu items can be found on page 20 to 34.



System Status • LED Indicators

RUN (Green)

Illuminates when the power is on and the microcontroller status is in normal run mode. The LED flashes once every 2 seconds when the system is in STANDBY mode.

ØA, ØB and ØC (Green)

Illuminates when the line voltage power is within the acceptable range of 100-130 VAC for each phase and the zero-cross reference circuitry is functioning properly. The LED will flash slowly (once per second) when an under-voltage state of less than 100 VAC is sensed and will flash quickly (twice per second) when an over-voltage of greater than 130 VAC is sensed.

DMX A and DMX B (Yellow)

Illuminates when valid DMX is received on each of the inputs. Flashes when invalid DMX is received.

ALARM

Illuminates and flashes twice per second when either a fire or security alarm is sensed on each of the inputs.

O/T

Illuminates and flashes twice per second whenever one of four over-temperature sensing inputs are triggered.

System Status • LCD Display

When DMX is being received, the top line of the LCD display shows the active DMX MODE ("PTY A", "PTY B", "MERGE", "DMX A+B", "2 ROOM" or "PATCH"). When DMX is not being received, the top line of the LCD display shows "MADD-96", unless the system is in standby mode, then "STANDBY!" is displayed.

The bottom line of the LCD Display shows the current status of the system unless the system configuration menu items are being accessed. Below are descriptions for each status indication.

NO RX!

Displayed when DMX is not being received on either input and the system is not in scene mode.

AXXXBXXX

Displayed when valid DMX is being received on one or both inputs and both inputs are not terminated. "A" and "B" represent the DMX A and DMX B inputs, while "XXX" represents the number of channels being received in each packet of data. For example, if the system is receiving 512 channels on DMX B and DMX A is disconnected the display will show "A000B512".

^T XXX ^T XXX _M _M

Same as above except the "A" and "B" is replaced with "^T_M" to indicate if one or both of the DMX inputs are terminated. For example, if the system is receiving 48 channels on DMX A and 512 channels on DMX B with only DMX A terminated, the display will show "^T_M048B512". Refer to menu items "DMXA TRM" and "DMXB TRM" on page 23 for further details.

SH XX:YY

Displayed when DMX is disconnected and the systems predetermined DMX status hold (SH) time is counting down. "XX" represents minutes, while "YY" represents seconds. Refer to menu item "SH TIME" on page 25 for further details.

**INF HOLD**

Displayed when DMX is disconnected and the systems predetermined DMX status hold (SH) time is set for infinite (INF) hold. Refer to menu item "SH TIME" on page 25 for further details.

SCENE:XX

Displays the scene (1 to 20) that is currently activated. The colon in front of the scene number flashed twice per second during fading. Refer to menu item "SCENEMOD" on page 28 for further details.

A-SCENE!

Displayed when the auxiliary input is triggered. Refer to menu item "AUX IN" on page 28 for further details.

FIRE!!!

Displayed when the fire alarm input is triggered. Refer to menu item "F-ALARM" on page 29 for further details.

SECURITY

Displayed when the security alarm input is triggered. Refer to menu item "S-ALARM" on page 28 for further details.

EXT-TEMP

Displayed when one or both of the two external over-temperature inputs is triggered. When the EXT-TEMP is triggered all dimmer outputs are disabled and the fans are turned on to full until the external devices temperature drops to within specification. See Over-Temperature Input information on page 14 for further details.

REM-TEMP

Displayed when the systems remote temperature sensor measures an over-temperature condition of 185°F (85°C) or more. All dimmer outputs are disabled and the fans are turned on to full until the temperature cools down to 178°F (81°C) or less. The "REM TEMP" feature is not used with CD-3000 Series retrofit systems. See menu item "REM TEMP" to view the current remote temperature.

CTL-TEMP

Displayed when the microcontroller senses an internal over-temperature condition of 185°F (85°C) or more. All dimmer outputs are disabled and the fans are turned on to full until the temperature cools down to 178°F (81°C) or less. See menu item "CTL TEMP" to view the current microcontroller temperature.

Ø ERROR!

Displayed when an error is sensed on any of the input power phases. A phase error can be caused from an under-voltage of less than 100VAC, an over-voltage of greater than 130VAC, or if a zero-cross phase reference is not detected.

RTC ERR!

Displayed when the system detects a runtime counter (RTC) error. This occurs when there is an invalid hard-key code and the runtime counter is greater than 2160 hours (90 days). Refer to menu item "HARD-KEY" on page 30 for further details.

LOCKED!!

Displayed when an attempt is made to access the system configuration menu items and the programming switches are locked out. To toggle between "LOCKED!!" and "UNLOCKED" press and hold down the "EXECUTE" and then "ESCAPE" switches at the same time for 4-5 seconds. Also displayed when an attempt is made to access factory only setup menus.



Quick Programming Reference to System Configuration Menu Items

1. SCENESET	Enable and setup 20 different backup scenes.
2. FADETIME	Set the fade time for each of the 20 scenes from 0 to 99 seconds.
3. SNAPSHOT	Record DMX levels into the backup scenes.
4. DIM TEST	Test the dimmer outputs one at a time, or all at once.
5. MONITOR	View the control level to each dimmer output.
6. ADDRESS	Set the DMX start address.
7. DMX MODE	Configure the mode of the on-board DMX protocol manager.
8. 2 RM SET	Set the two room assignment for each of the dimmer outputs.
9. DMXA TRM	Enable or disable termination on the DMX A input.
10. DMXB TRM	Enable or disable termination on the DMX B input.
11. DMX O/P	Configure the on-board DMX protocol manager for offset or patch mode.
12. DMXA PAT	Patch the 96 dimmer (PWM) outputs to any DMX A input channel.
13. DMXB PAT	Patch the 96 dimmer (PWM) outputs to any DMX B input channel.
14. SH TIME	Set the DMX status hold time from 0 to 99 minutes or infinite.
15. DC PATCH	Configure the dimmer to channel patch for the dimmer rack.
16. DIM CURV	Configure the dimmer curve for each output.
17. ND-LEVEL	Set the non-dim trigger level threshold for each output.
18. VOUT LIM	Set the maximum RMS output voltage for each dimmer.
19. REGULATE	Enable or disable the dimmer output voltage regulation.
20. ANA MODE	Configure the analog inputs for normal or load shed mode.
21. ANA PAT	Patch the analog inputs to any combination of control channels.
22. ANA TEST	View the control level for each of the analog inputs.
23. ANA FLTR	Apply a noise filter on the analog inputs of up to 1 Volt.
24. ANA BLOC	Enable or disable the analog inputs when DMX is being received.
25. STANDBY	Enable or disable the power savings standby mode.
26. TEST INC	Set the test increment units to percent or hexadecimal.
27. OC MODE	Configure the input trigger parameters for the open collector output.
28. AUX IN	Select which scene the auxiliary input will trigger/enable.
29. SCENEMOD	Enable or disable scene mode and the auxiliary input.
30. S-ALARM	Select the level and control channels triggered by the security alarm input.
31. F-ALARM	Select the level and control channels triggered by the fire alarm input.
32. Ø-PATCH	Set the zero-cross phase reference for each dimmer control output circuit.
33. WARMING	Turn the "lamp warming" feature on or off.
34. POLARITY	Set the PWM output control polarity. Locked for factory use only!
35. LINE V	View the RMS line voltage for each power phase.
36. LINE F	View the line frequency of phase A.
37. REM TEMP	View the temperature of the remote temperature sensor.
38. CTL TEMP	View the temperature of the microcontroller.
39. RTIME	View the total run time of the microcontroller.
40. HARD-KEY	View the microcontroller's unique six-character hard-key code.
41. SERIAL#	View the microcontroller's unique six-character silicone serial number.
42. VERSION	View the microcontroller's firmware version.
43. EEPROM	View the type of EEPROM memory module plugged in.
44. FW-LOAD	Load new firmware into the MADD-96 via the EEPROM memory module.
45. RESTORE	Restore parameters saved in the EEPROM memory module.
46. BACKUP	Backup parameters and save them in the EEPROM memory module.
47. PRINTOUT	Print various system configuration settings using a hand held infrared printer.
48. DEFAULTS	Set various system configuration settings to the factory default.
49. LCD VIEW	Adjust the contrast of the LCD Display for optimum viewing.



Detailed Programming of System Configuration Menu Items



NOTE: The programming switches can be locked out to prevent inadvertent configuration changes. To toggle between "LOCKED!!" and "UNLOCKED" press and hold down the EXECUTE and then ESCAPE switches at the same time for 4-5 seconds.

The sequence of the following system configuration menu items appear as the MENU DOWN (↓) switch is pressed. Pressing the MENU UP (↑) switch will sequence the system configuration menu items in the opposite order. Pressing and holding either of the MENU UP/DOWN (⬆) switches will speed up the scroll rate, which can be helpful to speed up the configuration time.

1. SCENESET

Enable and setup 20 different backup scenes.

When scene mode is activated the selected scene will be held with no timeout until the menu is exited. The 96 control channel levels are configured within the menu and can be modified on the fly. Scene mode is useful when an external controller is not available and independent internal control is required.

Press EXECUTE to enter the menu and activate scene mode.

Displays the scene (01) to be activated.

Press MENU (⬆) to select a different scene from 01 to 20.

Control (CTRL) is ON via the selected scene.

Control (CTRL) is via DMX and takes priority over scene mode.

Control (CTRL) is via DMX status hold (HLD) and takes priority over scene mode.

Press EXECUTE to activate the selected scene.

The colon (:) flashes twice per second while fading to the selected scene.

The colon (:) stops flashing when fade is complete and the selected scene is active.

Press MENU (⬆) to select a different scene from 01 to 20.

Press EXECUTE to modify the selected scene.

The second line on the LCD indicates the control channel (C) and level (L).

Press MENU (⬆) to select the control channel (C) to modify from 01 to 96.

Press EXECUTE to toggle from channel (C>) to level (L>) selection.

Press ESCAPE to toggle from level (L>) to channel (C>) selection.

Press MENU (⬆) to select the output level (L) for the selected channel from 00 to FL.

Press EXECUTE to clear the selected preset, and set all channels to 00 level.

Press EXECUTE if you are sure to clear the selected preset.

Indicates the selected preset has been cleared.

Press ESCAPE to exit and the menu and save programmed scene levels.

Press ESCAPE to back-up within the menu, or exit/deactivate scene mode.

Press RESET to exit scene mode without saving programmed scene levels.

SCENE>01
SCENE>20
CTRL: ON
CTRL:DMX
CTRL:HLD
SCENE>20
SCENE:20
SCENE:20
SCENE>20
SCENE 20
C>01L 00
C>96L 00
C 96L>00
C>96L 00
C 96L>FL
CLEAR???
SURE ???
DONE !!!
WAIT...



NOTE: When scene mode is activated: DMX and DMX status hold (SH TIME) automatically takes precedence over scene mode. The analog input levels are merged (HTP) with the scene levels. If the analog inputs are configured for load shed mode the inputs will take precedence over the active scene. The security alarm (S-ALARM) input is merged (HTP) with the scene levels while the fire alarm (F-ALARM) input automatically takes precedence. Scene mode (SCENEMOD) and the auxiliary input (AUX IN) are temporarily enabled. Scene mode will only activate dimmers assigned to room "A".

2. FADETIME

Set the fade time for each of the 20 scenes from 0 to 99 seconds.

The factory default is 5 seconds for all 20 presets.

Press EXECUTE to enter the menu.

Displays the scene (S>01) and assigned fade time (T 05).

Press MENU (⬆) to select a different scene from 01 to 20.

Press EXECUTE to toggle between scene (S>) and fade time (T>) selection.

Press MENU (⬆) to select a different fade time from 00 to 99 seconds.

Press ESCAPE to exit the menu and save the selected fade time.

Press RESET to exit the menu without saving.

The menu will automatically timeout after 5 minutes of inactivity and save.

S>01T 05
S>20T 05
S 20T>05
S 20T>99



3. SNAPSHOT

Record DMX levels into the backup scenes.

Provides a quick and easy way to save control channel levels into each of the 01 to 20 backup scenes using a DMX source.

Press EXECUTE to enter the menu and activate snapshot mode.

SAVE >01
SCENE>20
SURE ???
DONE !!!
NO RX!

Press MENU () to select a different scene from 01 to 20.

Press EXECUTE to store DMX levels in the selected scene.

Press EXECUTE if you are sure the DMX levels are set as intended.

DMX levels have now been stored in the selected scene.

DMX is not being received on either input, so a snapshot is not possible.

Press ESCAPE to back-up within the menu, or exit/deactivate snapshot mode.

Press RESET to exit/deactivate snapshot mode.

4. DIM TEST

Test the dimmer outputs one at a time, or all at once.

A technician's best friend! Used for troubleshooting the dimmer outputs and field wiring to the load.

Press EXECUTE to enter the menu and activate dimmer test mode.

D 01L>00
D 01L>50
D 01L>FL
D>01L FL
D>ALL FL

Displays the active dimmer (D) and the test level (L).

Press MENU () to select the desired test level.

Press ESCAPE to toggle the test level from full-on (FL) and off (00).

Press EXECUTE to toggle between the dimmer (D>) and the test level (L>).

Press MENU () to select the active dimmer from 01 to 96 or ALL.

Press ESCAPE or RESET to exit the menu.

The menu will automatically timeout after 5 minutes of inactivity.

5. MONITOR

View the control level to each dimmer output.

The dimmer control level is displayed as a 9-bit value from 000 to 512. This menu does not timeout automatically and will continue to monitor indefinitely.

Press EXECUTE to enter the menu and activate monitor mode.

D>01L000
D>96L512

Press MENU () to select the dimmer (D) output to monitor from 01 to 96.

Display shows dimmer 96 has full-on control.

Press ESCAPE or RESET to exit the menu.



NOTE: The control value will not reach 512 when voltage output limiting is activated, or when regulation is enabled and the line voltage is greater than 118 VAC.

6. ADDRESS

Set the DMX start address.

The DMX start address can be assigned from 001 to 512 and is common to both DMX inputs.

When DMX MODE is set for DMX A+B operation, each of the DMX inputs can be assigned to a separate DMX start address. The DMX inputs are merged and DMX-B is offset by the number of DMX-A channels.

Press EXECUTE to enter the menu.

DMXA>001
DMXA>512
DMXA>001
DMXA>025
DMXB>001
DMXB>512
#CHA=>01
#CHA=>96

Displays the current DMX start address for both DMX inputs.

Press MENU () to modify and select the desired DMX start address.

Press both MENU () simultaneously to toggle to DMX start address 001.

Press EXECUTE to save the selected DMX start address.

* Press EXECUTE to advance to select the DMX-B start address.

* Press MENU () to modify and select the desired DMX start address.

* Press EXECUTE to advance to select the number of DMX-A channels.

* Press MENU () to modify the number of DMX-A channels from 01 to 96.

Press ESCAPE to exit the menu and save the selected DMX start address.

Press RESET to exit the menu without saving.

The menu will automatically timeout after 5 minutes of inactivity and save.



NOTE: * DMX MODE must be set for DMX A+B operation to access this feature.

NOTE: DMX O/P must be set to OFFSET mode for this menu to function.



7. DMX MODE

Configure the mode of the on-board DMX protocol manager.

There are five different mode settings for the DMX protocol manager.

Priority A (PTY A) and Priority B (PTY B) modes are intended for the implementation of a backup DMX source. Priority A (PTY A) sets the DMX A input as the priority, and ignores the DMX B input when the DMX A input is active. Priority B (PTY B) sets the DMX B input as the priority, and ignores the DMX A input when the DMX B input is active.

Merge (MERGE) mode combines both DMX inputs with highest-takes-precedence (HTP) operation. Merge mode allows for simultaneous DMX control of the dimmers from both inputs, and is the default for the system.

Dual Universe DMX (DMX A+B) mode provides a method to combine two universes of DMX within one system. It permits two independent DMX sources to be active on the DMX inputs, with each having a separate DMX start address. The DMX inputs are merged and DMX-B is offset by the number of DMX-A channels programmed via the ADDRESS menu (see page 21 for further details). This feature is typically used when a system is at the end of one DMX universe (DMX-A) and the beginning of another (DMX-B).

Two Room (2 ROOM) mode enables the room (A or B) assignment for each of the dimmer outputs via the 2 RM SET menu.

PTY A

Press EXECUTE to toggle into Priority A (PTY A) mode.

PTY B

Press EXECUTE to toggle into Priority B (PTY B) mode.

MERGE

Press EXECUTE to toggle into Merge (MERGE) mode.

DMX A+B

Press EXECUTE to toggle into Dual Universe DMX (DMX A+B) mode.

2 ROOM

Press EXECUTE to toggle into Two Room (2 ROOM) mode.

Press ESCAPE or RESET to exit the menu.

Any change in the configuration is automatically saved.



NOTE: DMX O/P must be set to OFFSET mode for this menu to function.

8. 2 RM SET

Set the two room assignment for each of the dimmer outputs.

This menu is used to assign each of the 96 dimmer outputs to room "A" or room "B". Dimmer outputs assigned to room "A" are controlled via the DMX-A input. Dimmer outputs assigned to room "B" are controlled via the DMX-B input. This creates separation within the dimmer rack and makes a single dimmer rack function as though it is two independent dimmer racks. When used in conjunction with the DC PATCH menu, the dimmer rack can be configured for sequential DMX control of two rooms, even if the dimmer room assignments are not sequential.

DMX MODE must be set for 2 ROOM operation for this menu to function.

Press EXECUTE to enter the menu and activate 2 RM SET mode.

DIM 01 A

Displays the dimmer (DIM) output (01) and the room assignment (A).

DIM 96 A

Press MENU () to select a different dimmer output from 01 to 96.

DIM 96 B

Press EXECUTE to toggle the room assignment from A to B.

Press ESCAPE or RESET to exit the menu.

Any change in the configuration is automatically saved.



NOTE: Scene mode (SCENESET) will only activate/control dimmers assigned to room "A".

NOTE: DMX O/P must be set to OFFSET mode for this menu to function.



9. DMXA TRM

Enable or disable termination on the DMX A input.

Activates and deactivates a 120Ω termination resistor. DMX termination is indicated on the LCD display when DMX is being received. When the DMX A input is not terminated (DISABLED) the LCD display will read AXXXBXXX. When the DMX A input is terminated (ENABLED) the LCD display will read \bar{M} XXXBXXX.

ENABLED

Press EXECUTE to toggle termination from ENABLED to DISABLED.

DISABLED

Press EXECUTE to toggle termination from DISABLED to ENABLED.

Any change in the configuration is automatically saved.



NOTE: Ensure **only** the last (end-of-line) DMX receiving device is terminated!

10. DMXB TRM

Enable or disable termination on the DMX B input.

Activates and deactivates a 120Ω termination resistor. DMX termination is indicated on the LCD display when DMX is being received. When the DMX B input is not terminated (DISABLED) the LCD display will read AXXXBXXX. When the DMX B input is terminated (ENABLED) the LCD display will read AXXX \bar{M} XXX.

ENABLED

Press EXECUTE to toggle termination from ENABLED to DISABLED.

DISABLED

Press EXECUTE to toggle termination from DISABLED to ENABLED.

Any change in the configuration is automatically saved.



NOTE: Ensure **only** the last (end-of-line) DMX receiving device is terminated!

11. DMX O/P

Configure the on-board DMX protocol manager for offset or patch mode..

OFFSET mode is typically used for the majority of systems, and is the factory default. OFFSET mode refers to the DMX start address, with each of the 96 dimmer (PWM) outputs addressed sequentially from the DMX start address.

PATCH mode provides full flexibility for addressing each of the 96 dimmer (PWM) outputs. Each of the 96 dimmer (PWM) outputs can be patched to (controlled from) any DMX input channel from 001 to 512, from either or both of the DMX A and DMX B inputs simultaneously

With DMX patch mode activated, any configuration within the ADDRESS, DMX MODE, 2 RM SET and DC PATCH menus is ignored, and the DMX patch configured within the DMXA PAT and DMXB PAT menus takes precedence.

When using the system in DMX patch mode, it is strongly recommended to printout the patch using a hand held infrared printer (Johnson System Inc., Part Number: JS-IP). Press EXECUTE to enter the menu and configure the DMX mode.

DISABLED

This menu is disabled to help prevent inadvertent changes. Proceed to enable.

ENABLED

Press and hold MENU (↓) and MENU (↑) at the same time for 4-5 seconds.

OFFSET

Press EXECUTE to toggle the DMX mode from OFFSET to PATCH.

PATCH

Press EXECUTE to toggle the DMX mode from PATCH to OFFSET.

Press ESCAPE or RESET to exit the menu.

Any change in the configuration is automatically saved.

12. DMXA PAT

Patch the 96 dimmer (PWM) outputs to any DMX A input channel.

There are two ways to configure the DMX patch. Each of the 96 dimmer (PWM) outputs can be manually (MANUAL) patched to a DMX input channel, or patched in blocks (BLOCK) of sequential dimmers and DMX channels.

For MANUAL patching, each of the dimmers are patched individually. First, the dimmer (DIM) output is selected, and then any DMX input channel from 001 to 512 is patched to the selected dimmer.

For BLOCK patching, a sequential range of dimmers are patched to a sequential range of DMX channels. First, the first dimmer number (DIM#) in the block is selected, then the DMX A start address (DMXA) for the block is selected, and then finally the number of dimmers (#DIM) in the block is selected. For example, if DIM# is 001, DMX is 001, and #DIM is 096, then all of the dimmer outputs, 001 thru 096 are addressed sequentially to DMX channels 001 thru 096.



For a more complex example, if DIM# is 049, DMX is 321, and #DIM is 024, then dimmer outputs 049 thru 073 are addressed sequentially to DMX channels 321 thru 344. Using a combination of MANUAL and BLOCK patching methods can speed up configuration. Typically, a BLOCK of dimmers is first patched and then edited using the MANUAL patch.

The DMX patch should be cleared (CLEAR) before configuring the patch. Clearing the patch ensures all previously configured patch data is cleared (erased).

When DMXA PAT is utilized in conjunction with DMXB PAT, each of the 96 dimmer (PWM) outputs can be patched to (controlled from) any DMX input channel from 001 to 512, from either or both of the DMX A and DMX B inputs simultaneously.

If a dimmer is patched to both DMX A and DMX B input channels, the DMX levels are merged and highest-takes-precedence (HTP).

Press EXECUTE to enter the menu and configure the DMX A patch.

Press MENU (\blacktriangle) to scroll through and select the patching method.

Press EXECUTE to patch each of the dimmers manually (MANUAL).

The top line shows the dimmer (DIM) and (DMXA) address headings.

The second line shows the dimmer (DIM) and (DMXA) address values.

Press MENU (\blacktriangle) to select the dimmer (DIM) from 001 to 096 to patch.

Press MENU (\blacktriangle) and MENU (\blacktriangledown) at the same time to toggle back to 001.

Press EXECUTE to advance and select the DMXA address for the dimmer.

DMXA is initialized at 999 to indicate the dimmer is not patched.

? indicates the DMXA address (513 to 999) is invalid and is not patched.

The cursor ($_$) position indicates the DMXA digit to be edited.

Press EXECUTE to move the cursor to the right, under the digit to be edited.

Press ESCAPE to move the cursor to the left or to exit the menu.

Press MENU (\blacktriangle) to select the DMXA address from 001 to 512.

Press MENU (\blacktriangle) and MENU (\blacktriangledown) at the same time to toggle back to 999.

Repeat until all required dimmers are manually patched.

Press EXECUTE to patch the dimmers in a sequential block (BLOCK).

Press EXECUTE to select the first dimmer number (DIM#) in the block.

Press MENU (\blacktriangle) to edit the dimmer number (DIM#) from 001 to 096.

Press MENU (\blacktriangle) and MENU (\blacktriangledown) at the same time to toggle back to 001.

Press EXECUTE to select the DMX A (DMXA) start address for the block.

Press MENU (\blacktriangle) to edit the DMX A (DMXA) start address from 001 to 512.

Press MENU (\blacktriangle) and MENU (\blacktriangledown) at the same time to toggle back to 001.

Press EXECUTE to select the number of dimmers (#DIM) in the block.

Press MENU (\blacktriangle) to edit the number of dimmers (#DIM) from 001 to 096.

Press MENU (\blacktriangle) and MENU (\blacktriangledown) at the same time to toggle back to 001.

Press EXECUTE to proceed.

Press EXECUTE to proceed.

Indicates the sequential block patch has been completed.

Repeat until all required blocks of sequential dimmers have been patched.

Press ESCAPE to exit the menu.

Press EXECUTE to clear the entire patch.

Press EXECUTE to proceed.

Indicates the entire patch has been cleared.

Press ESCAPE to exit the menu and save the selected patch.

Press RESET to exit the menu without saving.

The menu will automatically timeout after 5 minutes of inactivity and save.

MANUAL?
DIM DMXA
001<999?
096<999?
001<999?
001 999?
001 999?
001 999?
001 999?
001 999?
001 999?
001 512
001 999?

BLOCK?
DIM#:001
DIM#:096
DIM#:001
DMXA:001
DMXA:512
DMXA:001
#DIM:001
#DIM:096
#DIM:001
PROCEED?
SURE ???
DONE !!!

CLEAR???
SURE ???
DONE !!!



NOTE: Be sure to BACKUP any configuration changes!

NOTE: With DMX patch mode activated, any configuration within the ADDRESS, DMX MODE, 2 RM SET and DC PATCH menus is ignored, and the DMX patch configured within this menu takes precedence.



13. DMXB PAT

Patch the 96 dimmer (PWM) outputs to any DMX B input channel.

Refer to the DMXA PAT menu for further information.

The DMXA PAT menu is used to patch dimmers to DMX A input channels, while the DMXB PAT menu is used to patch dimmers to DMX B input channels.

14. SH TIME

Set the DMX status hold time from 0 to 99 minutes or infinite.

When DMX is disconnected the system will hold the status of the last received DMX levels for the selected amount of time. When activated, the LCD display shows a countdown of the status hold time or infinite hold.

Press EXECUTE to enter the menu.

HTIME 00
HTIME 99
HTIME XX
HTIME 00

Displays the current DMX status hold time (HTIME) setting.

Press MENU () to set the desired hold time from 00 to 99 minutes.

Press MENU () to set the desired hold time to infinite (XX).

Press both MENU () switches to toggle back to status hold time of 00.

Press ESCAPE to exit the menu and save the desired DMX status hold time.

Press RESET to exit the menu without saving.

The menu will automatically timeout after 5 minutes of inactivity and save.

15. DC PATCH

Configure the dimmer to channel patch for the dimmer rack.

Each of the 96 dimmer (PWM) outputs can be assigned and patched to any of the 96 control channels. Multiple dimmer outputs may be patched to a single control channel. The dimmer to channel patch is used by other menu features to provide transparent control of the dimmer output circuits. CD-3000 systems are typically patched for 1 to 1 operation but may be altered for custom applications.

Press EXECUTE to enter the menu.

D01<C01
D96<C96
D96 C96<
D96 C01<
D96<C01

Displays the dimmer (D) output (01) and its current control channel (C) patch (01).

Press MENU () to select the desired dimmer output from 01 to 96.

Press EXECUTE to toggle the pointer (<) to select the control channel to patch.

Press MENU () to select the desired control channel from 01 to 96.

Press EXECUTE to toggle the pointer (<) to select another dimmer output.

Press ESCAPE to exit the menu and save the desired dimmer channel patch.

Press RESET to exit the menu without saving.

The menu will automatically timeout after 5 minutes of inactivity and save.



NOTE: DMX O/P must be set to OFFSET mode for this menu to function.

16. DIM CURV

Configure the dimmer curve for each output.

There are four different dimmer curve profiles that can be assigned to each individual dimmer output circuit. Square Law (SQ) curve is the industry standard and the default for all dimmers. Linear (LN) curve modifies the dimmer output for a linear relationship to the control input level. Direct Drive (DD) curve is not modified - meaning the control input level is directly proportional to the control output level. Non-Dim (ND) curve assigns the dimmer circuit to operate in a full-on or off state only, with no dimming. Dimmers set for non-dim (ND) will be triggered full-on at the ND-LEVEL setting.

Press EXECUTE to enter the menu.

DIM01 SQ
DIM96 SQ
DIM96 LN
DIM96 DD
DIM96 ND

Displays the dimmer (DIM) output (01) and its current dimmer curve.

Press MENU () to select the desired dimmer number from 01 to 96.

Press EXECUTE to toggle to linear (LN) curve mode.

Press EXECUTE to toggle to direct drive (DD) mode.

Press EXECUTE to toggle to non-dim (ND) mode.

Press ESCAPE to exit the menu and save the desired dimmer curves.

Press RESET to exit the menu without saving.

The menu will automatically timeout after 5 minutes of inactivity and save.



17. ND-LEVEL

Set the non-dim trigger level threshold for each output.

The non-dim trigger level threshold can be set for each of the 96 dimmer (PWM) outputs. The trigger level setting is only relevant when the dimmer curve profile is set to non-dim (ND). The trigger level can be set from 10% to 100% DMX control input, with 10% increments. There is 5% hysteresis to ensure there is no false triggering. When the trigger level is set to 10%, the output is turned full-on at 10% and off at 5%. When the trigger level is set to 100%, the output is turned full-on at 100% and off at 95%. The default trigger level is 10%.

Press EXECUTE to enter the menu.

D01<010%

Displays the dimmer (D) output (01) and the trigger level setting (010%).

D96<010%

Press MENU () to select the desired dimmer output from 01 to 96.

D96>010%

Press EXECUTE to toggle the pointer (>) to set the non-dim trigger level.

D96>100%

Press MENU () to set the trigger level from 10% to 100% DMX control.

D96<100%

Press EXECUTE to toggle the pointer (<) to select another dimmer output.

Press ESCAPE to exit the menu and save the desired trigger level settings.

Press RESET to exit the menu without saving.

The menu will automatically timeout after 5 minutes of inactivity and save.



NOTE: DIM CURV must be set to ND for this menu to function.

18. VOUT LIM

Set the maximum RMS output voltage for each dimmer.

Limiting the maximum RMS voltage can greatly improve lamp life.

Press EXECUTE to enter the menu.

01<127.5

Displays the dimmer (01) and its current maximum output voltage level (127.5).

96<127.5

Press MENU () to select the desired dimmer number from 01 to 96.

96>127.5

Press EXECUTE to toggle the pointer (< >) to select the output voltage level.

96>100.0

Press MENU () to adjust the output voltage level in 0.5 Volt increments.

96<100.0

Press EXECUTE to toggle the pointer (< >) to select another dimmer number.

Press ESCAPE to exit the menu and save the desired dimmer curves.

Press RESET to exit the menu without saving.

The menu will automatically timeout after 5 minutes of inactivity and save.

19. REGULATE

Enable or disable the dimmer output voltage regulation.

With the on-board output voltage regulation feature enabled the maximum RMS output is limited to 118 Volts. Voltage regulation automatically adjusts the internal control level to compensate for any line voltage fluctuations.

ENABLED

Press EXECUTE to toggle regulation from ENABLED to DISABLED.

DISABLED

Press EXECUTE to toggle regulation from DISABLED to ENABLED.

Any change in the configuration is automatically saved.

20. ANA MODE

Configure the analog inputs for normal or load shed mode.

Each of the four (4) analog inputs can be independently configured for normal (NORM) or load shed (SHED) mode of operation.

Normal (NORM) mode sets the analog input for 0-10VDC operation. The analog voltage level sensed sets the level for the selected dimmer outputs.

Load shed (SHED) mode is used as a power management interface to building management systems (BMS). Contact closure devices such as a photocell or maintained switch contact may be used to trigger the analog input. When a voltage of 5.5VDC to 12VDC is sensed on the analog input the selected dimmer outputs are disabled (set to zero output level). The selected dimmer outputs are enabled when the voltage sensed on the analog input drops to below 4.5VDC.

Press EXECUTE to enter the menu and set the mode for each analog input.



A01<NORM Displays the active analog input (A01) and current mode setting (NORM).
A04<NORM Press MENU (\blacklozenge) to select the desired analog input to configure.
A04<SHED Press EXECUTE to toggle from normal (NORM) to load shed (SHED) mode.
Press ESCAPE to exit the menu and save the desired analog input modes.
Press RESET to exit the menu without saving.
The menu will automatically timeout after 5 minutes of inactivity and save.

21. ANA PAT

Patch the analog inputs to any combination of control channels.

Press EXECUTE to enter the menu and activate analog patch mode.
A01<C01 Displays the active analog input (A01) and control channel (C01).
A04<C01 Press MENU (\blacklozenge) to select the desired analog input to patch.
A04>C01 Press EXECUTE to toggle the pointer (>) to select the control channel.
A04>C96 Press MENU (\blacklozenge) to select the desired control channel from 01 to 96.
A04>C96 * Press EXECUTE to patch and flag (*) the control channel to the analog input.
A04<C96 * Press ESCAPE to toggle the pointer (< >) to select another analog input.
Press ESCAPE to exit the menu and save the desired analog patches.
Press RESET to exit the menu without saving.
The menu will automatically timeout after 5 minutes of inactivity and save.

22. ANA TEST

View the control level for each of the analog inputs.

The analog voltage level for the 4 analog inputs can be tested and viewed as a percentage or hexadecimal value. The level displayed is proportional to the 0-10VDC analog input where 5VDC is 50%.
Press EXECUTE to enter the menu and activate analog test mode.
AI>01=00 Displays the active analog input (AI>01) and the level (00).
AI>04=00 Press MENU (\blacklozenge) to select the desired analog input to test.
AI>04=FL Displays the analog input level from off (00) to full-on (FL).
Press ESCAPE or RESET to exit the menu.

23. ANA FLTR

Apply a noise filter on the analog inputs of up to 1 Volt.

High frequency noise can sometimes be induced into the analog input lines. The analog filter is set in 1% increments where each percent (%) represents 0.1 Volts for a maximum filter level of 1 Volt, or 10%. For example, when the analog filter level is set at 5% (LEV:05%) all analog input levels at or below 0.5 Volts is ignored or filtered out.
LEV:00% Displays the filter level (00%) in percent.
LEV:00%< Press EXECUTE to enter the menu and adjust the analog filter level.
LEV:10%< Press MENU (\blacklozenge) to select the desired filter level.
Press ESCAPE to exit the menu and save the desired analog filter level.
Press RESET to exit the menu without saving.
The menu will automatically timeout after 5 minutes of inactivity and save.

24. ANA BLOC

Enable or disable the analog inputs when DMX is being received.

When analog blocking (ANA BLOC) is enabled the analog inputs will be ignored when DMX is online. When analog blocking is disabled the analog inputs will be merged/ combined with the DMX inputs and functions in a highest-takes-precedence (HTP) mode of operation.
ENABLED Press EXECUTE to toggle analog blocking from ENABLED to DISABLED.
DISABLED Press EXECUTE to toggle analog blocking from DISABLED to ENABLED.
Any change in the configuration is automatically saved.



25. STANDBY

Enable or disable the power savings standby mode.

When standby mode is enabled the microcontroller goes to sleep within 5 seconds of inactivity on the control inputs. The microcontroller wakes up again when a programming switch is pressed or when control is sensed on the control inputs. Note that there is a delay of 150 milliseconds for the microcontroller to wake up and restart normal run mode.

ENABLED
DISABLED

Press EXECUTE to toggle standby mode from ENABLED to DISABLED.

Press EXECUTE to toggle standby mode from DISABLED to ENABLED.

Any change in the configuration is automatically saved.

26. TEST INC

Set the test increment units to percent or hexadecimal.

The levels for the dimmer test (DIM TEST) and analog test (ANA TEST) features can be displayed as a percentage or hexadecimal value.

PERCENT
HEX VAL

Press EXECUTE to toggle test increments from PERCENT to HEX VAL.

Press EXECUTE to toggle test increments from HEX VAL to PERCENT.

Any change in the configuration is automatically saved.

27. OC MODE

Configure the input trigger parameters for the open collector output.

The on-board open collector output is used to sink up to 100mA of current. It can be configured to be triggered via a selected DMX channel, analog input 4, or both. The open collector is triggered on at 55% control input and triggered off again at 45% control input. When analog and DMX (A+D) is selected to trigger the open collector the inputs are combine for highest takes precedence (HTP).

A+D< 001
A+D> 001
A+D> 512
A+D< 512
DMX< 512
ANA<
OFF<

Press EXECUTE to enter the menu and configure the open collector output.

Displays the active trigger mode as analog and DMX (A+D<) channel 001.

Press EXECUTE to toggle the pointer (>) and select the DMX channel.

Press MENU (\blacktriangle) to change and select the DMX channel from 001 to 512.

Press EXECUTE to toggle the pointer (<) and select a different trigger mode.

Press MENU (\blacktriangle) to select DMX input trigger mode.

Press MENU (\blacktriangle) to select analog (ANA) input trigger mode.

Press MENU (\blacktriangle) to deactivate (OFF) the open collector output.

Press ESCAPE to exit the menu and save the desired settings.

Press RESET to exit the menu without saving.

The menu will automatically timeout after 5 minutes of inactivity and save.

28. AUX IN

Select which scene the auxiliary input will trigger/enable.

When a contact is sensed on the auxiliary input the selected scene will be triggered and held until the contact is removed. The auxiliary input only functions when scene mode (SCENESET) is activated or when the systems scene mode (SCENEMOD) is enabled and active.

SCENE:01
SCENE>01
SCENE>20

Displays the scene (01) that will be triggered by the auxiliary input.

Press EXECUTE to enter the menu and select a different scene.

Press MENU (\blacktriangle) to change the selected scene from 01 to 20.

Press ESCAPE to exit the menu and save the desired scene to be triggered.

Press RESET to exit the menu without saving.

The menu will automatically timeout after 5 minutes of inactivity and save.

29. SCENEMOD

Enable or disable scene mode and the auxiliary input.

Enabling scene mode puts the system in scene mode. With scene mode enabled the selected scene will always be activated when DMX is not being received. The selected scene can be changed in the SCENESET menu. Scene mode enables the use of the auxiliary input. A contact closure sensed on the over-temperature, fire alarm or security alarm inputs automatically takes precedence over scene mode.

ENABLED
DISABLED

Press EXECUTE to toggle scene mode from ENABLED to DISABLED.

Press EXECUTE to toggle scene mode from DISABLED to ENABLED.

Any change in the configuration is automatically saved.



30. S-ALARM

Select the level and control channels triggered by the security alarm input.

When a contact is sensed on the security alarm input, the selected control channels will cycle on and off at a 1 hertz rate. The level of the on cycle can be set from 0% to 100%. The security alarm input takes precedence over the DMX and analog inputs. The system will stay in security alarm mode until the contact is removed.

Press EXECUTE to enter the menu and configure the security alarm input.

L>FL:01*

Displays the output level (L>FL) of 100% and control channel (01*).

L>00:01*

Press MENU (\blacktriangle) to change the output level from 00% to 100% (FL).

L>FL:01*

Press MENU (\blacktriangledown) at the same time to toggle the level back to 100% (FL).

L:FL>01*

Press EXECUTE to toggle the pointer (>) and select the control channel(s).

L:FL>96*

Press MENU (\blacktriangle) to select the desired control channel from 01 to 96.

L:FL>96

Press EXECUTE to toggle the flag (*) for each desired control channel.

Press ESCAPE to exit the menu and save the desired settings.

Press RESET to exit the menu without saving.

The menu will automatically timeout after 5 minutes of inactivity and save.

31. F-ALARM

Select the level and control channels triggered by the fire alarm input.

When a contact is sensed on the fire alarm input, the selected control channels are triggered on to the selected output level from 0% to 100%. The fire alarm input is merged with the DMX and analog inputs with highest takes precedence (HTP). The system will stay in fire alarm mode until the contact is removed.

Press EXECUTE to enter the menu and configure the fire alarm input.

L>FL:01*

Displays the output level (L>FL) of 100% and control channel (01*).

L>00:01*

Press MENU (\blacktriangle) to change the output level from 00% to 100% (FL).

L>FL:01*

Press MENU (\blacktriangledown) at the same time to toggle the level back to 100% (FL).

L:FL>01*

Press EXECUTE to toggle the pointer (>) and select the control channel(s).

L:FL>96*

Press MENU (\blacktriangle) to select the desired control channel from 01 to 96.

L:FL>96

Press EXECUTE to toggle the flag (*) for each desired control channel.

Press ESCAPE to exit the menu and save the desired settings.

Press RESET to exit the menu without saving.

The menu will automatically timeout after 5 minutes of inactivity and save.

32. Ø-PATCH

Set the zero-cross phase reference for each dimmer control output circuit.

Strand CD80 dimmer racks are typically powered by 3-phase, with the dimmer phase reference configured for AABBC (dimmers 1 and 2 are powered by phase A, dimmers 3 and 4 are powered by phase B, dimmers 5 and 6 are powered by phase C, etc). The defaults (DEFAULTS) menu is normally used to configure the phase patch for standard applications. This menu provides custom phase patching for non-standard applications.

If a dimmer control output is patched to the incorrect phase reference, the dimmer will not dim correctly and will go to full output at around 1% DMX input..

Press EXECUTE to enter the menu and configure the dimmer phase patch.

CH 01 ØA

Displays the dimmer output channel (CH 01) and patched Phase A (ØA).

CH 96 ØA

Press MENU (\blacktriangle) to change the dimmer output channel to patch from 01 to 96.

CH 96 ØB

Press EXECUTE to toggle the patch to Phase B (ØB).

CH 96 ØC

Press EXECUTE to toggle the patch to Phase C (ØC).

Press ESCAPE to exit the menu and save the desired settings.

Press RESET to exit the menu without saving.

The menu will automatically timeout after 5 minutes of inactivity and save.



33. WARMING

Turn the "lamp warming" feature on or off.

The unique "lamp warming" feature is activated by a control level above 0% and lowers the in-rush current to the dimmer (cold lamp filament) by up to 70%. This results in significantly increased lamp filament life and lower long-term operating costs.

WARMING is set to ON by factory default, but may be turned OFF for some installation applications. With WARMING set to ON, a maximum delay of 245 milliseconds is introduced to "warm" the lamp when it is turned on. For fast chase effects the delay may be undesirable, in which case, the "lamp warming" feature can be turned off. Note that when standby mode is enabled the microcontroller goes to sleep within 5 seconds of inactivity on the control inputs, and there is delay of 150 milliseconds for the microcontroller to wake up and restart normal run mode. To ensure virtually instant dimmer control response, set STANDBY to DISABLED and WARMING to OFF.

Press EXECUTE to enter the menu and configure the lamp warming mode.

This menu is disabled to help prevent inadvertent changes. Proceed to enable.

Press and hold MENU (↓) and MENU (↑) at the same time for 4-5 seconds.

Press EXECUTE to toggle the lamp warming mode from ON to OFF.

Press EXECUTE to toggle the lamp warming mode from OFF to ON.

Press ESCAPE or RESET to exit the menu.

Any change in the configuration is automatically saved.

- DISABLED
- ENABLED
- ON
- OFF

34. POLARITY

Set the PWM output control polarity. Locked for factory use only!

This menu is only used when swapping control modules between CD-3000-AE and CD-3000-SV retrofit systems. CD-3000-AE systems utilize a positive going PWM output control signal while the CD-3000-SV systems utilize a negative going PWM output control signal.

Press EXECUTE to enter the menu and configure the polarity mode.

This menu is for factory use, and is disabled for the end user.

Press and hold MENU (↓) and MENU (↑) at the same time for 4-5 seconds.

Press EXECUTE to toggle the PWM output polarity from POSITIVE to NEGATIVE.

Press EXECUTE to toggle the PWM output polarity from NEGATIVE to POSITIVE.

Press ESCAPE to exit the menu and save the desired setting.

Press RESET to exit the menu without saving.

The menu will automatically timeout after 5 minutes of inactivity and save.

- DISABLED
- ENABLED
- POSITIVE
- NEGATIVE

35. LINE V

View the RMS line voltage for each power phase.

Press EXECUTE to enter the menu and view the line voltage of each phase.

- ØA=120.0
- ØB=120.0
- ØC=120.0

Shows the line voltage of Phase A.

Press MENU (⬆) to view the line voltage of Phase B.

Press MENU (⬇) to view the line voltage of Phase C.

Press ESCAPE or RESET to exit the menu.

36. LINE F

View the line frequency of phase A.

- 60.0 Hz

Shows the frequency.

37. REM TEMP

View the temperature of the remote temperature sensor.

The remote temperature sensor is not used in CD-3000 Series retrofit systems and will always read 32°F or 0°C.

- +032°F
- +000°C

Shows the temperature in degrees Fahrenheit.

Press EXECUTE to toggle units to degrees Celsius.



38. CTL TEMP

+91°F
+33°C

View the temperature of the microcontroller.
Shows the temperature in degrees Fahrenheit.
Press EXECUTE to toggle units to degrees Celsius.

39. RTIME

RTIME SS
HHHHH:MM

View the total run time of the microcontroller.
The run time counter keeps track of the total time the microcontroller is powered up. The maximum time is 99999 hours, 59 minutes, 59 seconds, or about 11.4 years. System operation is not effected when the maximum run time is reached and can be reset to zero at the factory.
Shows the number of seconds (SS) of run time.
Shows the number of hours (HHHHH) and minutes (MM) of run time.

40. HARD-KEY

HARD-KEY
HARD KEY
K:XXXXXX
K:XXXXXX
K:XXXXXX
K>XXXXXX
K>XXXXXX
K:>XXXXX
K:>XXXXX
K:X>XXXX
K:X>XXXX
K:XX>XXX
K:XX>XXX
K:XXX>XX
K:XXX>XX
K:XXXX>X
K:XXXX>X

View the microcontroller's unique six-character hard-key code.
CD-3000 Series retrofit control systems may be shipped with an invalid hard-key code of 000000. A valid hard-key must be entered before the run time (RTIME) counter reaches 2160 hours / 90 days. If the run time expires without a valid hard-key the LCD display will show a runtime counter error (RTC ERR!) and all dimmer control outputs will be disabled.
A dash (-) between hard and key represents a valid hard-key.
A blank space between hard and key represents an invalid hard-key.
Shows the unique six-character hard-key code (XXXXXX).
Follow the procedure below to enter the menu and modify the hard-key.
Press and hold EXECUTE and then ESCAPE at the same time for 4-5 seconds.
A pointer (>) appears to indicate hard-key modification is activated.
Press MENU (⬇) to modify the first hard-key character.
Press EXECUTE to advance to the second hard-key character.
Press MENU (⬇) to modify the second hard-key character.
Press EXECUTE to advance to the third hard-key character.
Press MENU (⬇) to modify the third hard-key character.
Press EXECUTE to advance to the fourth hard-key character.
Press MENU (⬇) to modify the fourth hard-key character.
Press EXECUTE to advance to the fifth hard-key character.
Press MENU (⬇) to modify the fifth hard-key character.
Press EXECUTE to advance to the sixth hard-key character.
Press MENU (⬇) to modify the sixth hard-key character.
Press ESCAPE to exit the menu and save the desired hard-key code.
Press RESET to exit the menu without saving.
The menu will automatically timeout after 5 minutes of inactivity and save.



NOTE: Be sure to record and file the hard-key code on page 35 for future reference.

41. SERIAL#

XXXXXX

View the microcontroller's unique six-character silicone serial number.
Shows the unique six-character serial number.

42. VERSION

VER X.X

View the microcontroller's software version.
Shows the microcontroller's software version.



43. EEPROM

View the type of EEPROM memory module plugged in.

All CD-3000 Series retrofit control systems come with a removable EEPROM memory module located on the MADD-96 board in the control module. The EEPROM memory module inserts into the PORT4 connector located on the upper left-hand side of the board, and may be removed for safe storage.

The EEPROM type is programmed for parameter (P) or firmware (F) operation. A parameter EEPROM is used to backup all of the current configuration settings. A firmware EEPROM is used to update the current firmware version running on the MADD-96 microcontroller to the firmware version saved on the EEPROM.

The EEPROM memory module supplied with all CD-3000 Series retrofit systems is a parameter type with all of the factory default configuration settings saved onto it before shipping.

- MADD96-P Indicates the EEPROM memory module is for a MADD-96 microcontroller.
- MADD96-P Indicates the EEPROM type is programmed for parameter (P) operation.
- XXXXXX Press EXECUTE to display the silicone serial number parameter.
- DISABLED Press EXECUTE and menu feature is disabled for factory use only.
- MADD96-F Indicates the EEPROM type is programmed for firmware (F) operation.
- VER X.X Press EXECUTE to display the version (VER) of the firmware.
- DISABLED Press EXECUTE and menu feature is disabled for factory use only.
- NONE! Indicates the EEPROM memory module is not installed.

44. FW-LOAD

Load new firmware into the MADD-96 via the EEPROM memory module.

If a firmware update is required, Johnson Systems Inc. may supply an EEPROM memory module with the latest firmware version. The firmware EEPROM memory module can be inserted into PORT4 on the MADD-96 board and the firmware can be loaded into the microcontroller.

Press EXECUTE to enter the menu.

- DISABLED This menu is disabled for inadvertent use. Proceed to enable.
- ENABLED Press and hold MENU (↓) and MENU (↑) at the same time for 4-5 seconds.
- MEMCHECK Automatically checks the EEPROM memory module for firmware type.
- CRC-TEST Automatically does a CRC test on the firmware code in the EEPROM.
- >>>>>>> The CRC test in progress.
- VER X.X Displays the firmware version on the EEPROM memory module.
- UPDATE?? Press EXECUTE to proceed.
- SURE ??? Press EXECUTE to proceed.
- UPDATING Firmware update in progress.
- WILL Firmware update in progress.
- AUTO Firmware update in progress.
- RESTART Firmware update in progress.
- PLEASE Firmware update in progress.
- WAIT... When firmware update is complete the RUN LED flashes and system restarts.
- NO MEM! Displayed if an EEPROM memory module is not detected.
- WRONG Displayed if the wrong type (parameter) of EEPROM memory module detected.
- MEM TYPE Displayed if the wrong type (parameter) of EEPROM memory module detected.
- WRONG Displayed if the wrong product type of EEPROM memory module detected.
- PRODUCT Displayed if the wrong product type of EEPROM memory module detected.
- CRC ERR! Displayed if the CRC test fails and the EEPROM memory module is defective.



WARNING: Do not reset or turn the power off while the firmware is being updated. Doing so will cause unrecoverable loss of firmware data that is being loaded into the MADD-96 microcontroller.



45. RESTORE

Restore parameters saved in the EEPROM memory module.

All of the configuration setting parameters can be restored from EEPROM memory module if they have been inadvertently changed or corrupted. This feature can also be used to load configuration setting parameters into a different or new control module. This reduces the configuration time for multi-system applications that require similar settings or when a replacement control module is required.

Press EXECUTE to enter the menu.

- DISABLED This menu is disabled for inadvertent use. Proceed to enable.
- ENABLED Press and hold MENU (↓) and MENU (↑) at the same time for 4-5 seconds.
- MEMCHECK Automatically checks the EEPROM memory module for parameter type.
- OKAY... The EEPROM memory module has been verified for parameter type.
- PROCEED? Press EXECUTE to proceed.
- SURE ??? Press EXECUTE to proceed.
- CRC-TEST Automatically does a CRC test on the parameter code in the EEPROM.
- WAIT CRC test in progress.
- VERIFY CRC test in progress.
- DONE!! CRC test is done and the parameter restore automatically begins.
- WILL Parameter restore in progress.
- AUTO Parameter restore in progress.
- RESTART When parameter restore is complete, the system restarts.
- SERIAL # Displayed when the silicone serial number on the EEPROM memory module is a mismatch with the silicone serial number on the MADD-96 microcontroller.
- PROCEED? Press EXECUTE to proceed.
- NO MEM! Displayed if an EEPROM memory module is not detected.
- WRONG Displayed if the wrong type (parameter) of EEPROM memory module detected.
- MEM TYPE Displayed if the wrong type (parameter) of EEPROM memory module detected.
- WRONG Displayed if the wrong product type of EEPROM memory module detected.
- PRODUCT Displayed if the wrong product type of EEPROM memory module detected.
- ERROR Displayed when an error occurs. Waits for key press to restart RESTORE.

46. BACKUP

Backup parameters and save them in the EEPROM memory module.

All of the configuration setting parameters can be saved in the EEPROM memory module for backup. The backup parameters can then be restored if they have been inadvertently changed or corrupted. Once backup is complete the EEPROM memory module may be removed for safe storage. All CD-3000 Series retrofit control systems are shipped with the factory default settings saved in the EEPROM memory module.

Press EXECUTE to enter the menu.

- DISABLED This menu is disabled for inadvertent use. Proceed to enable.
- ENABLED Press and hold MENU (↓) and MENU (↑) at the same time for 4-5 seconds.
- MEMCHECK Automatically checks the EEPROM memory module for parameter type.
- SURE ??? Press EXECUTE to proceed.
- WAIT Automatically begins parameter backup and generates CRC value.
- VERIFY Automatically verifies parameter backup data and CRC value.
- DONE!! Parameter backup is done and saved in the EEPROM memory module.
- NO MEM! Displayed if an EEPROM memory module is not detected.
- WRONG Displayed if the wrong type (parameter) of EEPROM memory module detected.
- MEM TYPE Displayed if the wrong type (parameter) of EEPROM memory module detected.
- WRONG Displayed if the wrong product type of EEPROM memory module detected.
- PRODUCT Displayed if the wrong product type of EEPROM memory module detected.
- DATA ERR Displayed when a data error occurs. Waits for key press to restart BACKUP.



NOTE: Backup all CD-3000 Series retrofit control systems when configuration is complete.



47. PRINTOUT

Print various system configuration settings using a hand held infrared printer.

All CD-3000 Series retrofit control systems come equipped with an infrared (I/R) LED that provides the ability to printout all the system configuration settings, when used in conjunction with a hand held infrared printer (Johnson System Inc., Part Number: JS-IP). Point the hand held printer I/R LED directly at the CD-3000 Control Module PRINTER I/R LED within 3 ft (1m).

Press EXECUTE to enter the menu.

Press MENU (\blacklozenge) to scroll through and select which item(s) to printout.

- SYSTEM? Prints general system information and configuration settings.
- ANALOGS? Prints the channel patch for all 4 analog inputs.
- Ø-PATCH? Prints the phase patch for all 96 dimmer outputs.
- CURVES? Prints the dimmer curves for all 96 dimmer outputs.
- F-ALARM? Prints the configuration settings for the fire alarm input.
- S-ALARM? Prints the configuration settings for the security alarm input.
- SCENE? Prints the level settings for each of the 96 dimmers within the 20 scenes.
- SCENE>01 Press EXECUTE to toggle the pointer (>) and select which scene to print.
- SCENE>FL Press MENU (\blacklozenge) to select the desired scene (01 to 20) or all scenes (FL).
- V-LIMIT? Prints the output voltage limit settings for each of the 96 dimmer outputs.
- DCPATCH? Prints the configuration settings for the dimmer to channel patch.
- FD-TIME? Prints the fade time settings for each of the 20 scenes.
- 2 ROOM? Prints the two room assignment for each of the 96 dimmer outputs.
- DMXAPAT? Prints the DMX A patch for each of the 96 dimmer outputs.
- DMXBPAT? Prints the DMX B patch for each of the 96 dimmer outputs.
- ND-LEVEL ALL? Prints the non-dim trigger level threshold setting for each of the 96 dimmer outputs. Printout all items at once.
- PRINTING Press EXECUTE on any item to begin printing. Press ESCAPE or RESET to exit the menu.

48. DEFAULTS

Set various system configuration settings to the factory default.

Press EXECUTE to enter the menu.

Press MENU (\blacklozenge) to scroll through and select which item(s) to default.

- ØPATCH1? Sets the dimmer phase patch to AABBC. This is the default setting.
- ØPATCH2? Sets the dimmer phase patch to AAAAAA.
- CURVES? Sets all 96 dimmer curve profiles to Square Law curve.
- ANA-OFF? Clears the control channel patch for all 4 analog inputs.
- V-LIMIT? Sets the output voltage limit to full (127.5) on all 96 dimmer outputs.
- DCPATCH? Clears the dimmer to channel patch and configures it for 1:1 operation.
- FD-TIME? Sets the fade time at 5 seconds for all 20 scenes.
- 2 ROOM? Sets the two room assignment to room "A" on all 96 dimmer outputs.
- ND-LEVEL SURE??? Sets the non-dim trigger level threshold to 10% on all 96 dimmer outputs. Press EXECUTE to select the item to default. Are you sure?
- DONE!!! Press EXECUTE to set the selected default. Press ESCAPE or RESET to exit the menu.

49. LCD VIEW

Adjust the contrast of the LCD Display for optimum viewing.

Press EXECUTE to enter the menu.

ADJUST \blacktriangledown \blacktriangle Press MENU (\blacklozenge) to adjust the contrast.

Press ESCAPE to exit the menu and save the desired LCD view.

Press RESET to exit the menu without saving.

The menu will automatically timeout after 5 minutes of inactivity and save.

Important Hard-key Information

CD-3000 Series retrofit systems may be shipped with an invalid hard-key code of 000000. A valid hard-key must be entered before the run time (RTIME) counter reaches 2160 hours / 90 days. If the run time expires without a valid hard-key, the LCD display will show a runtime counter error (RTC ERR!) and all dimmer control outputs will be disabled.

Refer to menu item "HARD-KEY" on page 30 of the user manual for detailed instructions on how to enter a valid hard-key code. Be sure to record and file the valid hard-key code for future reference.

JSI Serial Number: _____
 Silicone Serial Number: _____
 Hard-Key Code: _____

JSI Serial Number: _____
 Silicone Serial Number: _____
 Hard-Key Code: _____

JSI Serial Number: _____
 Silicone Serial Number: _____
 Hard-Key Code: _____

JSI Serial Number: _____
 Silicone Serial Number: _____
 Hard-Key Code: _____

JSI Serial Number: _____
 Silicone Serial Number: _____
 Hard-Key Code: _____

JSI Serial Number: _____
 Silicone Serial Number: _____
 Hard-Key Code: _____

JSI Serial Number: _____
 Silicone Serial Number: _____
 Hard-Key Code: _____

JSI Serial Number: _____
 Silicone Serial Number: _____
 Hard-Key Code: _____

JSI Serial Number: _____
 Silicone Serial Number: _____
 Hard-Key Code: _____

JSI Serial Number: _____
 Silicone Serial Number: _____
 Hard-Key Code: _____

JSI Serial Number: _____
 Silicone Serial Number: _____
 Hard-Key Code: _____

JSI Serial Number: _____
 Silicone Serial Number: _____
 Hard-Key Code: _____

JSI Serial Number: _____
 Silicone Serial Number: _____
 Hard-Key Code: _____

JSI Serial Number: _____
 Silicone Serial Number: _____
 Hard-Key Code: _____

JSI Serial Number: _____
 Silicone Serial Number: _____
 Hard-Key Code: _____

JSI Serial Number: _____
 Silicone Serial Number: _____
 Hard-Key Code: _____

User Manual
CD-3000 Series Retrofit Control System
Rev. 5

www.johnsonsystems.com



JOHNSON SYSTEMS INC.

"PROFESSIONAL LIGHT CONTROL PRODUCTS"

1923 Highfield Crescent S.E.
Calgary, Alberta, Canada T2G 5M1
tel: 403.287.8003

fax: 403.287.9003

e-mail: info@johnsonsystems.com

website: www.johnsonsystems.com

